



THE LEADER IN FIRE PROTECTION

# Lifeco



## G B Automatic Sprinkler

Glass Bulb  
Upright, Pendent &  
Horizontal Side Wall

### Product description

The model LIFECO001-006 standard/Quick response sprinkler in nominal temperatures upto 93°C (200°F) are available in spray pendent, upright and Horizontal side wall.

These are incorporated with 5 / 3mm diameter glass bulb as a heat sensitive element.

### Operation

The glass bulb capsule contains a heat sensitive liquid that expands upon application of heat, at the rated temperature, the frangible capsule ruptures thereby releasing the orifice seal. The sprinkler then discharges water in a pre-designed spray pattern to control or extinguish the fire.

Approvals: UL

## Escutcheon plate

### Optional

One & Two piece escutcheon plates are designed to enhance the appearance of the pendent sprinklers when installed below the ceilings. The escutcheon provides a decorative closure of the annular space between the sprinkler and the ceiling.

**Standard finishes:** Chrome, Brass & White.  
Other colours available upon request.





# G B Automatic Sprinkler

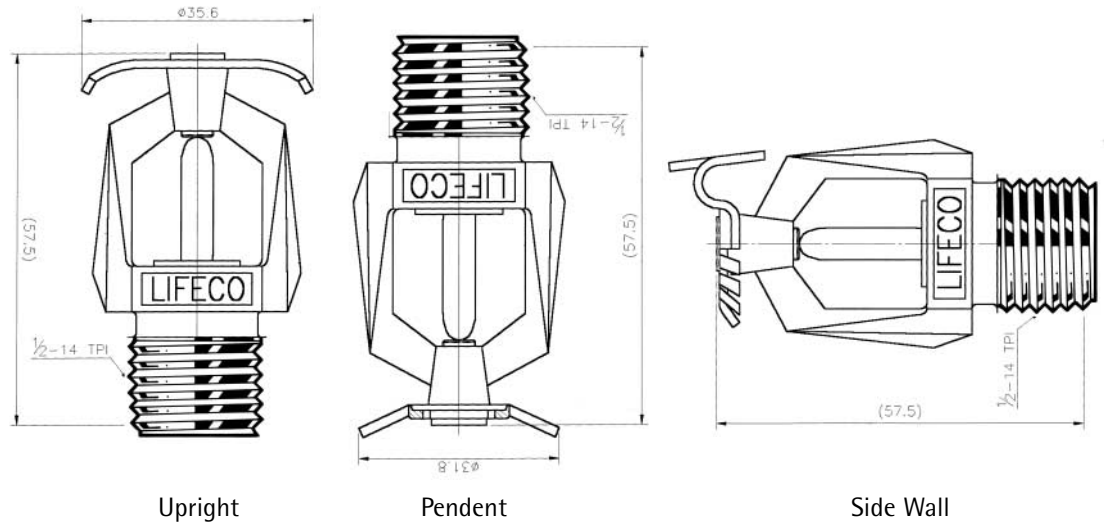

## Technical data

Model: LIFECO001/002/003/004/005/006.

Style: Pendant, Upright or Conventional & Side wall

Orifice size: 1/2"(12.7mm) NOM

K factor: 5.6

Thread size: 1/2" N.P.T male inlet

Maximum working pressure 175psi (12 bar)

Factory hydrostatic test pressure 100% at 500psi (34 bar)

Temp. Classification	Bulb Colour	Bulb Size / Temp.
Ordinary	Orange	5mm/57°C (135°F)
Intermediate	Red	5mm/68°C (155°F)
High	Yellow	3mm/79°C (175°F)
Extra high	Green	3mm/93°C (200°F)
Very extra high	Blue	141°C(286°F)
Ultra high	Mauve	182°C(360°F)

Lichfield Fire & Safety  
Equipment Co. Ltd  
2nd Floor, Suite 4, Saturn Centre  
Spring Road, Ettingshall  
Wolverhampton WV4 6JX  
United Kingdom.

Tel: +44 (0) 870 066 4401  
Fax: + 44 (0) 870 066 4402  
E-Mail: info@lifeco-uk.com  
Website: www.lifeco-uk.com

## Standard Finishes

Brass, Chrome, White Polyester Epoxy Powder

(other colours available to suit customer's individual requirements)

