



UL/FM

# Lifeco



## Gate Valve 2 1/2" to 12" Resilient Wedge OS & Y Rising Stem W.P 200Psi

Model 722 U

### FEATURES

- Meets or exceeds all requirements of AWWA C509
- Painted as standard
- Epoxy Coated inside and out to AWWA C550 upon request
- Flanged ends to ANSI B 16.1 Class 125
- Working Pressure:
  - 2 1/2" - 12": 200 psi non-shock cold water
  - Option: Stem available in Bronze (B62) or Stainless Steel (SUS304)

Size	Dimensions (mm)					Wt Kg
	A	B	C	D	E	
2 1/2"	191	391	178	178	17	20.20
3"	203	454	254	191	19	39.60
4"	229	562	254	229	24	46.50
6"	267	781	305	279	25	80.00
8"	292	930	356	343	29	129.00
10"	330	1174	406	406	30	197.40
12"	356	1397	457	483	32	276.00

No.	Part	Material	Standard
1	Body	Cast Iron	ASTM A126 Class B
2	Disc	Cast Iron	ASTM A126 Class B
3	Stem	Brass	ASTM B-16
4	Body Gasket	EPDM	Commercial
5	Bolt	Steel	ASTM A307-B
6	Nut	Steel	ASTM A307-B
7	Bonnet	Cast Iron	ASTM A126 Class B
8	Backseat Bushing	Cast Brass	ASTM B-584
9	Packing	Non-Asbestos	Commercial
10	Gland	Cast Bronze	ASTM B-62
11	Gland Follower Bolt	Steel	ASTM A307-B
12	Gland Follower Nut	Steel	ASTM A307-B
13	Gland Follower	Ductile Iron	ASTM A-536
14	Yoke Bushing	Cast Bronze	ASTM B-62
15	Yoke Bushing Nut	Ductile Iron	ASTM A-536
16	Screw	Steel	ASTM A307-B
17	Handwheel	Cast Iron	ASTM A126 Class B
18	Identification Plate	Aluminium	
19	Handwheel Nut	Ductile Iron	ASTM A-536

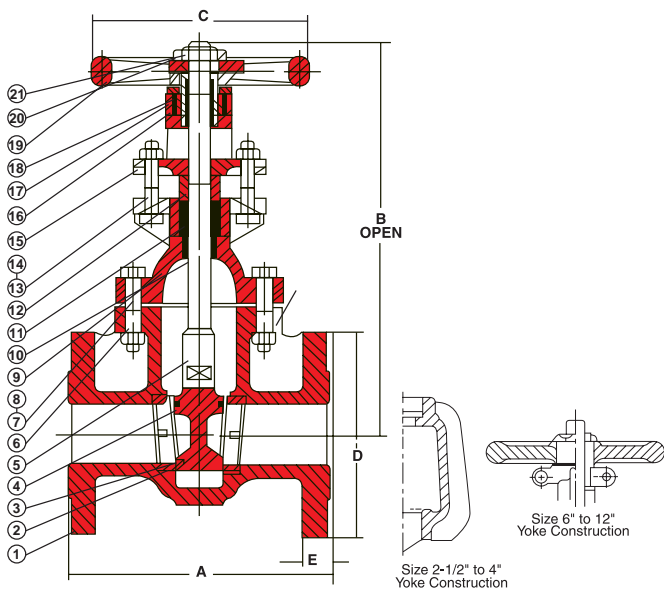

**Lichfield Fire & Safety  
Equipment Co. Ltd**  
Suite 4, 2nd floor, Saturn Centre  
Spring Road, Ettingshall  
Wolverhampton WV4 6JX  
United Kingdom.

Tel: +44 (0) 870 066 4401  
Fax: +44 (0) 870 066 4402  
E-Mail: [info@lifeco-uk.com](mailto:info@lifeco-uk.com)  
Website: [www.lifeco-uk.com](http://www.lifeco-uk.com)

