

DESCRIPTION & OPERATION

- The Series LF830, LF831, 5.6 K-factor, flat plate concealed pendent Sprinklers, standard coverage. Described in this data sheet LF830 is standard response, 5mm glass bulb type sprinkler; LF831 is quick response, 3mm glass bulb type sprinkler.

- The soldered cover plate drops off the retainer assembly when exposed to heat, as from a fire, that has reached the plate's Listed temperature rating exposing the sprinkler above. As heat encompasses the glass bulb operating element of the sprinkler, the fluid in the bulb expands, compressing the air bubble within the bulb. When the air bubble can no longer compress, the fluid expansion causes breakage of the glass bulb, resulting in release of the water seat assembly, and discharge of water from the sprinkler.



TECHNICAL SPECIFICATION

SIN	LF830	LF831
Style	Concealed Pendent	
K Factor	5.6 (80 metric)	
gpm/(psi) ^{1/2} (L ³ /min(bar) ^{1/2})	5.6 (80 metric)	
Nominal Thread Size	1/2" NPT OR 1/2" BSPT	
Max. Working Pressure	175 PSI (12BAR)	
RESPONSE	STANDARD	QUICK
Factory Test Pressure	500 PSI (35BAR)	
Min. Operating Pressure	7 PSI (0.5 BAR)	
Cover Plate Finishes	White Coating, Chrome, Bright Brass, Brass & Custom	

TEMPERATURE RATE

Concealed Pendent Sprinklers are available with variety of temperature ratings to meet different design requirements.

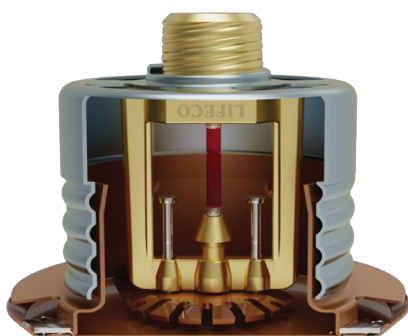

SIN	K-FACTOR	135°F (57°C) Cover Plate		165°F (74°C) Cover Plate	
		135°F (57°C) Sprinkler	155°F (68°C) Sprinkler	175°F (79°C) Sprinkler	200°F (93°C) Sprinkler
LF830,LF831	5.6	Y	Y	Y	Y

SPRINKLER MATERIALS

Part	Material
Load Screw	DZR Brass
Bulb Seat	Brass
Frame	DZR Brass
Seal	Beryllium Nickel w/Teflon
Deflector	Bronze
Support Cup	Steel
Guide Pins	Stainless Steel 316
Cover Plate	H62 Brass
Skirt	Brass
Ejection Spring	C5191

Drawing

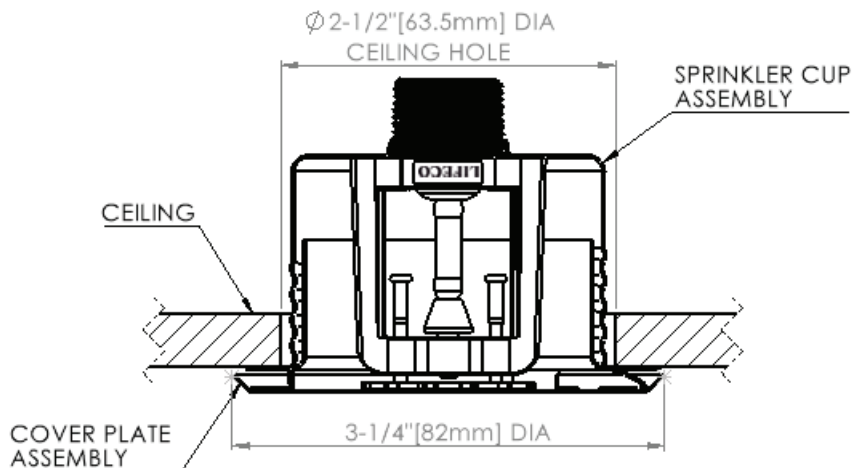

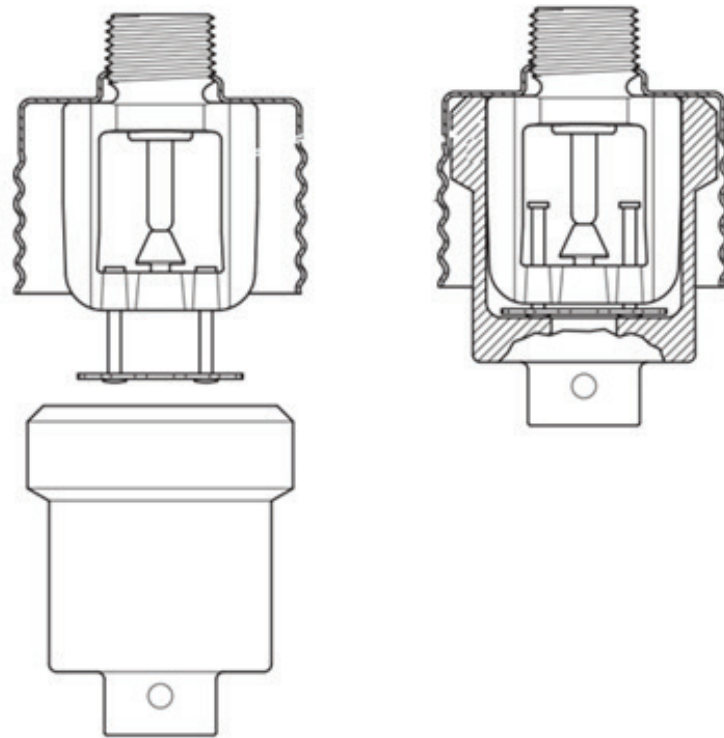

Caution :

It is recommended not to exceed 14 ft-lb torque for 1/2 inch NPT sprinkle threads.

*** Please ensure that the protective cover is removed where applicable before operating the sprinkler system.**