

Installation manual

LF-LED-600B

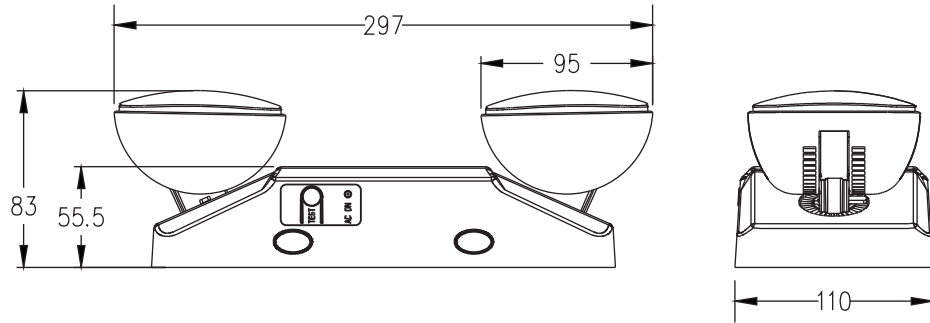

Warning note

If the external flexible cable or cord of this luminaire is damaged, it shall be exclusively replaced by the manufacturer or his service agent or a similar qualified person in order to avoid a hazard. the battery is non-replaceable.

Installation: The installation shall be done by a qualified person.

Model list:

Model name	LF-LED-600B
Rated voltage	AC120-347V~, 50/60Hz
Input Current	40mA
Input Wattage	2.5W
Output Wattage	2.4W
Emergency Run Time	3Hours
Correlated Color Temperature	6500K
Emergency Luminance Flux	180Lm
Battery	Ni-Cd 3.6V, 1800mAh
Battery life	up to 4 years
Power factor	>0.4
Charge Time	24 hours
Emergency Duration	3 hours
Operating Temp Range	0 C -40 C
Degree of Protection	IP20
Protection class	Class II
Dimensions	297×110×83mm
Weight	0.60kg
Warranty	2 years
Max. mounting height	10.5ft (3.1 m)

Installation instruction diagram:

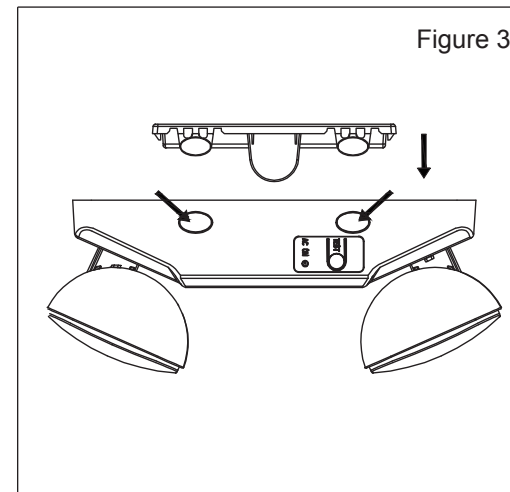
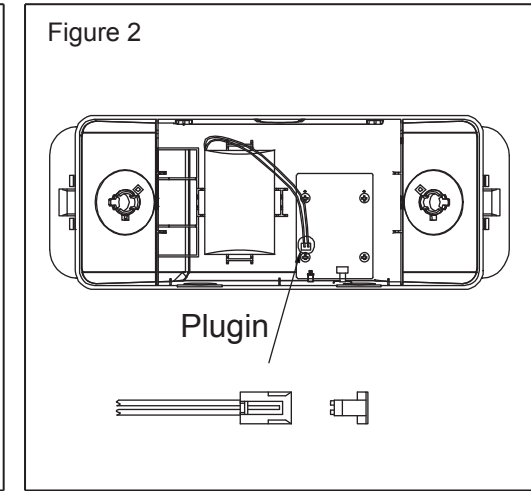
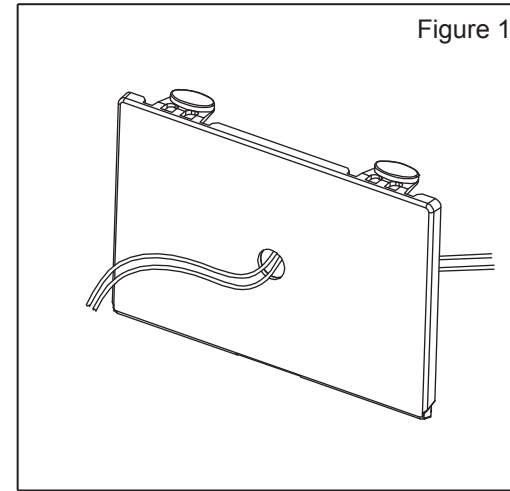

Installation Instructions J-Box Mounting

1. Feed fixture leads through main bottom case and connect AC power supply (Figure 1).
2. Connect wires through J-Box. Main bottom case on J-Box and secure with screws.
3. Connect battery only after continuous AC power can be provided to the unit (Figure 2).
4. Align snaps and push housing directly onto main bottom case (Figure 3). Apply continuous AC power and press "TEST" button to check light.

Installation Instructions Conduit

1. Secure main bottom case to wall surface. Route wires through hole in conduit flange and make conduit connection.
2. Connect battery only after continuous AC power can be provided to the unit (Figure 2)
3. Align snaps and push housing directly onto main bottom case (Figure 3). Apply continuous AC power and press "TEST" button to check light.

NOTE: To appear outside blue sleeve of terminal before connecting.

FLEXIBLE CONDUIT ONLY

READ AND FOLLOW ALL SAFETY INSTRUCTIONS

1. Disconnect power before performing work on electrical equipment.
2. For indoor use only.
3. Do not let the power cords touch hot surfaces.
4. Do not install in hazardous locations or near gas or electric heaters.
5. The use of auxiliary equipment not recommended by manufacturer, may cause and will void the unit's warranty.
6. Do not use this equipment for other than its intended purpose
7. Servicing of this equipment should be performed by a qualified service technician.
8. All electrical connections should be made in accordance with National and Regional electrical code.
9. Equipment should be mounted in locations and at heights where it will not readily be subjected to tampering by unauthorized personnel
10. Allow battery to charge for 24 hours before first use.

IMPORTANT

Battery in this unit may not be fully charged at the time electrical connection is made. Let battery charge for atleast 24 hours. Then nonmal operation of this unit should take effect. To check, press the "TEST" button, The light inside the unit should turn on. The lamps, when used according to these instruction with this unit equipment, are in accordance with the requirements of CSA standard C22.2 N0.141

Operation

1. During an electrical power failure, the lamps will automatically come on for a minimum of 180 minutes.
2. To test, depress the "TEST" switch, the emergency lamps will illuminate. When the switch is released, the lamps will go off.



This marking indicates that this product should not be disposed with other household wastes throughout the EU. To prevent possible harm to the environment or human health from uncontrolled waste disposal, recycle it responsibly to promote the sustainable reuse of material resources. To return your used device, please use the return and collection systems or contact the retailer where the product was purchased. They can take this product for environmental safe recycling.

