

BLADDER TANK PROPORTIONING SYSTEM



Lichfield Fire and Safety Equipment Co. Ltd.

Address: Unit 8, Calibre Industrial Park, Laches Close, Four Ashes,
Wolverhampton, WV10 7DZ, United Kingdom

Website: www.lifeco-uk.com

E-Mail: sales@lifeco-uk.com

ISSUE	1		
DATE	01/01/2003		
Prepd.	SHR	Chk.	Appvd.
DATA SHEET	LFB/001		

BLADDER TANK

BLADDER TANK PROPORTIONING SYSTEM

TECHNICAL DATA:

TANK MOUNTING TYPE	Vertical or Horizontal
CONCENTRATE STORAGE CAPACITY	For Vertical Tank: 150 litres to 5000 litres. For Horizontal Tank: 150 litres to 9000 litres.
RATED PRESSURE	12 Bar (175 psi)
FACTORY TEST PRESSURE	18 Bar (262 psi)
VESSEL CONSTRUCTION	Carbon steel to ASME Code Section VIII for unfired Pressure vessels.
BLADDER	Buna -N with nylon Reinforcement
CENTRE TUBE	PVC
EXTERNAL PIPING	Waterside: Carbon steel Seamless pipe sch 40. Foam concentrate side; SS Sch. 40
VENT AND DRAIN VALVE/ SS	Ball valve with Bronze /
OPTIONAL	Sight gauge with shut off and drain valve, ladder and concentrate supply control valve.
FINISH	Epoxy red painted.
ORDERING	Please specify
INFORMATION	1) Tank type, vertical or horizontal 2) Storage capacity of foam concentrate. 3) Model number, size of ratio controller with flow and pressure. 4) Type of foam concentrate to be used and percentage of induction required. 5) Field connection flange specification ANSI class 150# RF/FF.

APPLICATION

The Bladder Tank Foam Proportioning System utilizes the water pressure to inject foam concentrate into a water supply and automatically proportions foam concentrate over wide range of flow and pressure, with very low-pressure drop. This system does not require concentrate supply pump.

SPECIFICATION

The Bladder Tank Foam Proportioning System is available with vertical and horizontal bladder tanks. The carbon steel tanks are designed and constructed in accordance with ASME Code Section VIII for unfired pressure vessels. The maximum working pressure is 12 Bar (175 psi) and factory tested for 18 Bar (263 psi). A continuous skirt supports the vertical tank assembly with four feet drilled to it for anchoring. Two saddles welded to the tank and drilled for anchoring support the horizontal tanks. Tank is provided with lifting lugs.

The system is supplied with pressure vessel, bladder, fill and drain valve for water and foam concentrate, ratio controller and vent valve. The ladder and sight glass assembly is supplied as optional item on request.

PRINCIPLE OF OPERATION

The foam concentrate is to be filled into the bladder very carefully to avoid rupture of the bladder. The filling instruction is provided with the equipment. Once the main water flow is established and water inlet and foam outlet valves are opened, the water enters the area between vessel wall and bladder, applying pressure to the bladder. The foam concentrate is forced out of the bladder through the foam outlet pipe and into the ratio controller through metering orifice. The concentrate pressure and water inlet pressure at ratio controller will be same, as the main water supply pressure is utilized to expel the foam from the bladder. The water flowing through the ratio controller jet creates a low-pressure area common both to down stream water and foam concentrate. This injects the concentrate in to the ration controller through an accurate sized orifice proportioned to water venturi. This ensures correct proportioning over a wide range of flow condition.

The bladder tank proportioning system operates on same principle as that of a balance pressure proportioning system. In bladder system, the bladder is used as diaphragm to separate the water and foam concentrate within the tank. The foam concentrate is injected into the ratio controller utilizing water pressure.

A system is also supplied with foam concentrate control valve as an optional item. The valve allows concentrate flow only when minimum of 3.0 kg/sq.cm. Water pressure is established in the system. For pressure drop and flow characteristics refer catalogue of Ratio Controller.

NOTE:

These data sheets are the property of LIFECO. It shall not be reproduced, copied, lent in any manner or used for any other purpose other than that for which it is specially furnished, except by written permission of LIFECO.

We reserve the right to modify without prior notice for future development and enhancement of the product.

BLADDER TANK

BLADDER TANK PROPORTIONING SYSTEM

TECHNICAL DATA:

TANK MOUNTING TYPE	Vertical or Horizontal
CONCENTRATE STORAGE CAPACITY	For Vertical Tank: 150 litres to 5000 litres. For Horizontal Tank: 150 litres to 9000 litres.
RATED PRESSURE	12 Bar (175 psi)
FACTORY TEST PRESSURE	18 Bar (262 psi)
VESSEL CONSTRUCTION	Carbon steel to ASME Code Section VIII for unfired Pressure vessels.
BLADDER	Buna -N with nylon Reinforcement
CENTRE TUBE	PVC
EXTERNAL PIPING	Waterside: Carbon steel Seamless pipe sch 40. Foam concentrate side; SS Sch. 40
VENT AND DRAIN VALVE/ SS	Ball valve with Bronze /
OPTIONAL	Sight gauge with shut off and drain valve, ladder and concentrate supply control valve.
FINISH	Epoxy red painted.
ORDERING	Please specify
INFORMATION	1) Tank type, vertical or horizontal 2) Storage capacity of foam concentrate. 3) Model number, size of ratio controller with flow and pressure. 4) Type of foam concentrate to be used and percentage of induction required. 5) Field connection flange specification ANSI class 150# RF/FF.

APPLICATION

The Bladder Tank Foam Proportioning System utilizes the water pressure to inject foam concentrate into a water supply and automatically proportions foam concentrate over wide range of flow and pressure, with very low-pressure drop. This system does not require concentrate supply pump.

SPECIFICATION

The Bladder Tank Foam Proportioning System is available with vertical and horizontal bladder tanks. The carbon steel tanks are designed and constructed in accordance with ASME Code Section VIII for unfired pressure vessels. The maximum working pressure is 12 Bar (175 psi) and factory tested for 18 Bar (263 psi). A continuous skirt supports the vertical tank assembly with four feet drilled to it for anchoring. Two saddles welded to the tank and drilled for anchoring support the horizontal tanks. Tank is provided with lifting lugs.

The system is supplied with pressure vessel, bladder, fill and drain valve for water and foam concentrate, ratio controller and vent valve. The ladder and sight glass assembly is supplied as optional item on request.

PRINCIPLE OF OPERATION

The foam concentrate is to be filled into the bladder very carefully to avoid rupture of the bladder. The filling instruction is provided with the equipment. Once the main water flow is established and water inlet and foam outlet valves are opened, the water enters the area between vessel wall and bladder, applying pressure to the bladder. The foam concentrate is forced out of the bladder through the foam outlet pipe and into the ratio controller through metering orifice. The concentrate pressure and water inlet pressure at ratio controller will be same, as the main water supply pressure is utilized to expel the foam from the bladder. The water flowing through the ratio controller jet creates a low-pressure area common both to down stream water and foam concentrate. This injects the concentrate in to the ration controller through an accurate sized orifice proportioned to water venturi. This ensures correct proportioning over a wide range of flow condition.

The bladder tank proportioning system operates on same principle as that of a balance pressure proportioning system. In bladder system, the bladder is used as diaphragm to separate the water and foam concentrate within the tank. The foam concentrate is injected into the ratio controller utilizing water pressure.

A system is also supplied with foam concentrate control valve as an optional item. The valve allows concentrate flow only when minimum of 3.0 kg/sq.cm. Water pressure is established in the system. For pressure drop and flow characteristics refer catalogue of Ratio Controller.

NOTE:

These data sheets are the property of LIFECO. It shall not be reproduced, copied, lent in any manner or used for any other purpose other than that for which it is specially furnished, except by written permission of LIFECO.

We reserve the right to modify without prior notice for future development and enhancement of the product.

□ **VERTICAL BLADDER TANK**

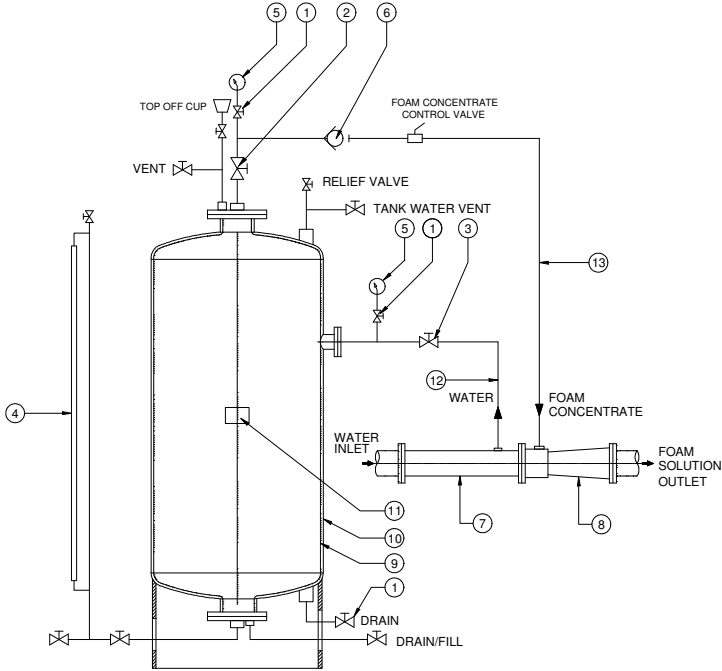

MATERIAL OF CONSTRUCTION

SR.NO	DESCRIPTION	SPECIFICATION
1	VALVE	SS/BRONZE
2	FOAM CONCENTRATE SHUT OFF VALVE	SS/BRONZE
3	WATER SHUT OFF VALVE	SS/BRONZE
4	LEVEL INDICATOR	GLASS/ACRYLIC
5	PRESSURE GAUGE	0-16 KG/SQ.CM.
6	CHECK VALVE	SS/BRONZE
7	SPOOL PIECE	CARBON STEEL
8	RATIO CONTROLLER	BRONZE
9	BLADDER	BUNA-N
10	TANK	CARBON STEEL
11	NAME PLATE	BRASS
12	WATER LINE PIPING	CARBON STEEL
13	FOAM CONCENTRATE PIPING	SS

NOTE:

*These data sheets are the property of **LIFECO**. It shall not be reproduced, copied, lent in any manner or used for any other purpose other than that for which it is specially furnished, except by written permission of **LIFECO**.*

We reserve the right to modify without prior notice for future development and enhancement of the product.

BLADDER TANK

VERTICAL BLADDER TANK

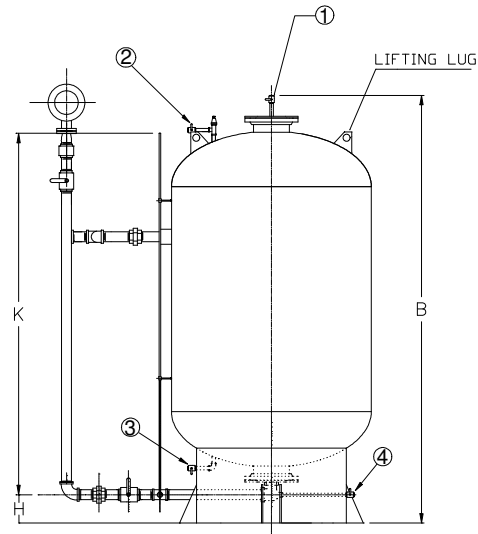
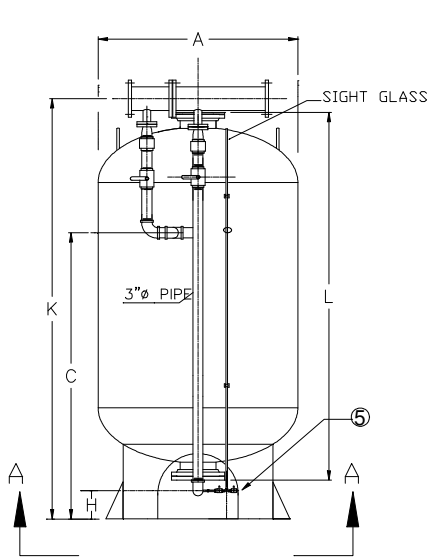
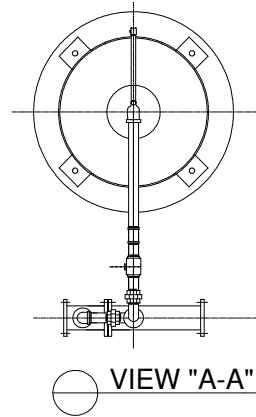
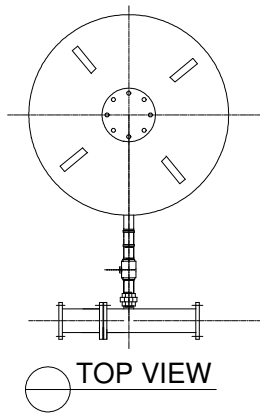

NOTE:

VALVE No.	DESCRIPTION	NORMAL
1	CONCENTRATE VALVE	CLOSED
2	TANK WATER VENT	CLOSED
3	WATER DRAIN/FILL	CLOSED
4	CONCENTRATE DRAIN/FILL	CLOSED
5	SIGHT GLASS VALVE	CLOSED

NOTE:

These data sheets are the property of **LIFECO**. It shall not be reproduced, copied, lent in any manner or used for any other purpose other than that for which it is specially furnished, except by written permission of **LIFECO**.

We reserve the right to modify without prior notice for future development and enhancement of the product.

BLADDER TANK

VERTICAL BLADDER TANK
CAPACITY & DIMENSION

CAPACITY GALS (LITRES)	TANK DIMENSIONS – INCHES (MM)										
	'A'	'B'	'C'	'D'	'E'	'F'	'G'	'H'	'J'	'K'	'L'
25 (95)	20(508)	46(1168)	24(610)	18-1/4(464)	9/16(14)	1-1/2(38)	13-3/4(349)	4-7/16(112)	2(51)	35-5/16(897)	
50(189)	20(508)	67(1701)	47(1193)	18-1/4(464)	9/16(14)	2(51)	13-3/4(349)	4-7/16(112)	2(51)	51-1/16(1297)	55-5/8(1413)
100(379)	24(610)	75(1904)	60(1523)	22-1/4(565)	9/16(14)	2(51)	17-3/4(451)	4-7/16(112)	2(51)	64-7/8(1648)	69-5/8(1768)
150(568)	30(762)	84(2132)	61-1/2(1561)	27-3/4(705)	9/16(14)	2(51)	20-3/4(527)	4-7/16(112)	2(51)	67-1/2(1715)	72-5/8(1854)
200(757)	30(762)	108(2742)	85-1/2(2170)	27-3/4(705)	9/16(14)	2(51)	20-3/4(527)	4-7/16(112)	2(51)	91-1/2(2324)	96-5/8(2459)
300(1136)	36(914)	111(2819)	87(2209)	32-3/4(832)	9/16(14)	2(51)	23-3/4(603)	4-7/16(112)	2(51)	93-1/2(2375)	98-3/4(2508)
400(1514)	42(1067)	113(2869)	87-1/2(2221)	37-1/2(953)	11/16(17)	2(51)	26-3/4(679)	4-7/16(112)	2(51)	96-11/16(2456)	101-3/4(2584)
500(1892)	42(1067)	117(2970)	91-1/2(2323)	37-1/4(947)	11/16(17)	2(51)	26-3/4(679)	4-7/16(112)	2(51)	112(2843)	109-3/4(2788)
600(2271)	48(1219)	116(2945)	89(2261)	41-1/2(1054)	11/16(17)	3(76)	29-3/4(756)	4-7/16(112)	3(76)	99-1/16(2516)	125-3/4(3194)
700(2650)	48(1219)	124(3148)	97(2462)	41-1/4(1057)	11/16(17)	3(76)	29-7/8(759)	4-7/16(112)	3(76)	123(3124)	118-3/4(3016)
800(3028)	48(1219)	140(3554)	113(2869)	41-1/4(1057)	11/16(17)	3(76)	29-7/8(759)	4-7/16(112)	3(76)	123-5/8(3140)	127-3/4(3245)
900(3407)	48(1219)	163(4138)	136(3453)	41-1/4(1057)	11/16(17)	3(76)	29-7/8(759)	4-7/16(112)	3(76)	146-1/4(3715)	146-3/4(3727)
1000(3785)	60(1524)	124(3148)	94(2386)	51-1/2(1308)	13/16(21)	3(76)	35-7/8(911)	8-7/16(214)	3(76)	104-9/16(2656)	162-3/4(4134)
1100(4164)	60(1524)	136(3454)	121(3072)	51-1/2(1308)	13/16(21)	3(76)	35-7/8(911)	8-7/16(214)	3(76)	116-1/2(2959)	174-3/4(4439)
1200(4542)	60(1524)	148(3757)	118(2996)	51-1/2(1308)	13/16(21)	3(76)	35-7/8(911)	8-7/16(214)	3(76)	129-1/2(3289)	134-13/16(3424)
1400(5300)	60(1524)	159(4037)	129(3275)	51-1/2(1308)	13/16(21)	3(76)	35-7/8(911)	8-7/16(214)	3(76)	140-1/2(3569)	145-13/16(3704)
1500(5678)	60(1524)	170(4136)	141(3579)	51-1/2(1308)	13/16(21)	3(76)	35-7/8(911)	8-7/16(214)	3(76)	152-1/2(3874)	157-13/16(4008)

NOTE:

These data sheets are the property of LIFECO. It shall not be reproduced, copied, lent in any manner or used for any other purpose other than that for which it is specially furnished, except by written permission of LIFECO.

We reserve the right to modify without prior notice for future development and enhancement of the product.

BLADDER TANK

HORIZONTAL BLADDER TANK

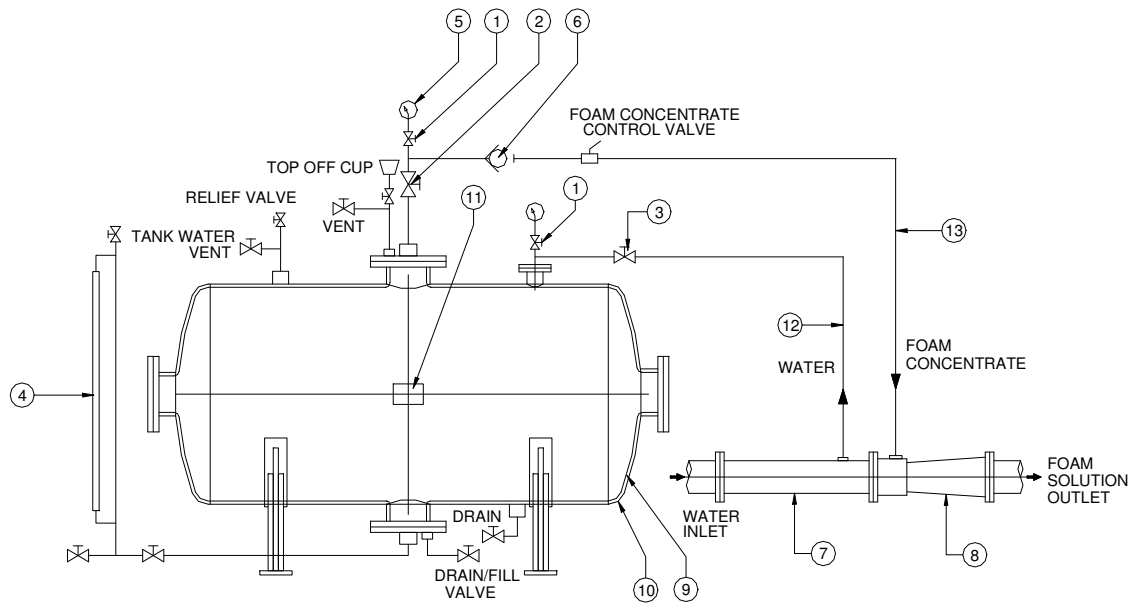

MATERIAL OF CONSTRUCTION

SR.NO	DESCRIPTION	SPECIFICATION
1	VALVE	SS/BRONZE
2	FOAM CONCENTRATE SHUT OFF VALVE	SS/BRONZE
3	WATER SHUT OFF VALVE	SS/BRONZE
4	LEVEL INDICATOR	GLASS/ACRYLIC
5	PRESSURE GAUGE	0-16 KG/SQ.CM.
6	CHECK VALVE	SS/BRONZE
7	SPOOL PIECE	CARBON STEEL
8	RATIO CONTROLLER	BRONZE
9	BLADDER	BUNA-N
10	TANK	CARBON STEEL
11	NAME PLATE	BRASS
12	WATER LINE PIPING	CARBON STEEL
13	FOAM CONCENTRATE PIPING	SS

NOTE:

These data sheets are the property of **LIFECO**. It shall not be reproduced, copied, lent in any manner or used for any other purpose other than that for which it is specially furnished, except by written permission of **LIFECO**.

We reserve the right to modify without prior notice for future development and enhancement of the product.

BLADDER TANK

HORIZONTAL BLADDER TANK

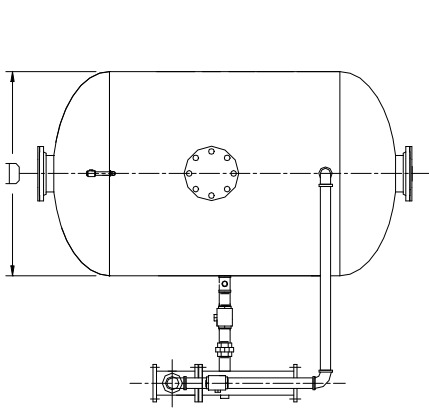

TOP VIEW

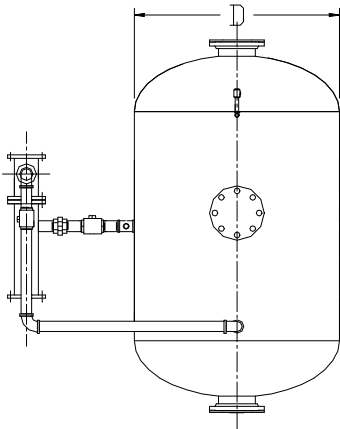

VIEW "A-A"

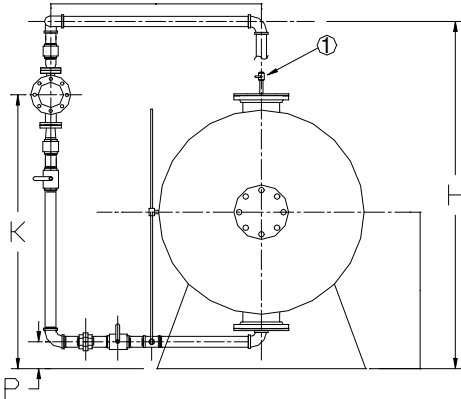
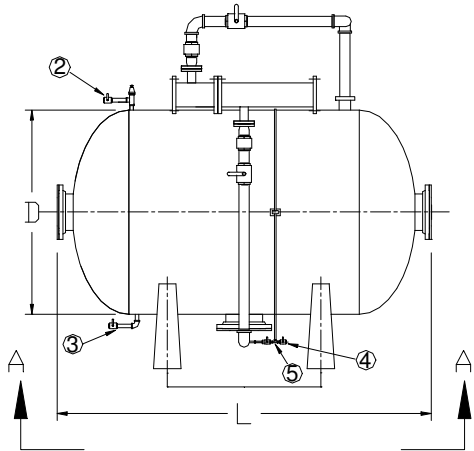

NOTE:

VALVE No.	DESCRIPTION	NORMAL
1	CONCENTRATE VALVE	CLOSED
2	TANK WATER VENT	CLOSED
3	WATER DRAIN/FILL	CLOSED
4	CONCENTRATE DRAIN/FILL	CLOSED
5	SIGHT GLASS	CLOSED

NOTE:

These data sheets are the property of **LIFECO**. It shall not be reproduced, copied, lent in any manner or used for any other purpose other than that for which it is specially furnished, except by written permission of **LIFECO**.

We reserve the right to modify without prior notice for future development and enhancement of the product.

BLADDER TANK

HORIZONTAL BLADDER TANK
CAPACITY & DIMENSION

CAPACITY GALS (LITRES)	"A"	"B"	"C"	"D"	"E"	"F"	"G"	"H"	"J"	"K"	"L"	"M"	"N"	"P"	"Q"
25 (95)	20(508)	14(356)	1-3/4(44)	20(508)	3(76)	9/16(14)	22(559)	40-5/16(1024)	14(356)	1(25)	55-5/8(1413)	2(51)	12(305)	4-7/16(113)	13(330)
50(189)	20(508)	14(356)	1-3/4(44)	24(610)	3(76)	9/16(14)	22(559)	40-5/16(1024)	14(356)	1(25)	55-5/8(1413)	2(51)	12(305)	4-7/16(113)	13(330)
100(379)	24(610)	18(457)	1-3/4(44)	24(610)	3(76)	9/16(14)	24(610)	44-5/16(1126)	22(559)	2(51)	69-5/8(1768)	2(51)	18(457)	4-7/16(113)	15(381)
150(568)	30(762)	22(559)	2-1/4(57)	30(762)	9/16(14)	9/16(14)	27(686)	50-5/16(1278)	20(508)	2(51)	72-5/8(1845)	2(51)	18-1/2(472)	4-7/16(113)	18(457)
200(757)	30(762)	22(559)	2-1/4(57)	30(762)	9/16(14)	9/16(14)	27(686)	50-5/16(1278)	44(1118)	2(51)	96-5/8(2454)	2(51)	30-1/2(775)	4-7/16(113)	18(457)
300(1136)	40(1016)	26(660)	2-1/4(57)	36(914)	9/16(14)	9/16(14)	30(762)	56-5/16(1430)	45(1143)	2(51)	98-3/4(2508)	2(51)	30(762)	4-7/16(113)	21(533)
400(1514)	40(1016)	30(762)	2-3/4(70)	42(1067)	11/16(17)	11/16(17)	33(838)	62-5/16(1583)	46(1168)	2(51)	101-3/4(2584)	2(51)	30(762)	4-7/16(113)	24(610)
500(1892)	40(1016)	30(762)	2-3/4(70)	42(1067)	11/16(17)	11/16(17)	33(838)	62-5/16(1583)	54(1372)	2(51)	109-3/4(2788)	3(76)	34(864)	8-7/16(214)	24(610)
600(2271)	40(1016)	30(762)	2-3/4(70)	42(1067)	11/16(17)	11/16(17)	33(838)	62-5/16(1583)	66(1676)	3(76)	125-3/4(3194)	3(76)	42(1067)	8-7/16(214)	24(610)
700(2650)	44(1118)	34(864)	2-3/4(70)	48(1219)	11/16(17)	11/16(17)	40(1016)	72-5/16(1837)	52(1321)	3(76)	118-3/4(3016)	3(76)	34(864)	8-7/16(214)	27-5/16(694)
800(3028)	44(1118)	34(864)	2-3/4(70)	48(1219)	11/16(17)	11/16(17)	40(1016)	72-5/16(1837)	62(1575)	3(76)	127-3/4(3245)	3(76)	38-1/2(978)	8-7/16(214)	27-5/16(694)
900(3407)	44(1118)	34(864)	2-3/4(70)	48(1219)	11/16(17)	11/16(17)	40(1016)	72-5/16(1837)	80(2032)	3(76)	146-3/4(3727)	3(76)	48(1219)	8-7/16(214)	27-5/16(694)
1000(3785)	44(1118)	34(864)	2-3/4(70)	48(1219)	13/16(21)	11/16(17)	40(1016)	72-5/16(1837)	106(2692)	3(76)	162-3/4(4134)	3(76)	56(1422)	8-7/16(214)	27-5/16(694)
1100(4164)	44(1118)	34(864)	2-3/4(70)	48(1219)	13/16(21)	11/16(17)	46(1168)	72-5/16(1837)	108(2743)	3(76)	174-3/4(4439)	3(76)	65(1575)	8-7/16(214)	27-5/16(694)
1200(4542)	54(1372)	44(1118)	3-1/2(89)	60(1524)	13/16(21)	11/16(17)	46(1168)	84-5/16(2142)	72(1829)	3(76)	134-13/16(3424)	3(76)	39(991)	8-7/16(214)	33-5/16(846)
1300(4920)	54(1372)	44(1118)	3-1/2(89)	60(1524)	6(152)	11/16(17)	46(1168)	84-5/16(2142)	72(1829)	3(76)	139-13/16(3551)	3(76)	41-1/2(1054)	8-7/16(214)	33-5/16(846)
1400(5300)	54(1372)	44(1118)	3-1/2(89)	60(1524)	6(152)	11/16(17)	46(1168)	84-5/16(2142)	84(2134)	3(76)	145-13/16(3704)	3(76)	44-1/2(1143)	8-7/16(214)	33-5/16(846)
1500(5678)	54(1372)	44(1118)	3-1/2(89)	60(1524)	6(152)	11/16(17)	52(1321)	84-5/16(2142)	94(288)	3(76)	157-13/16(4008)	3(76)	50-1/2(1283)	8-7/16(214)	33-5/16(846)
1600(6057)	64(1626)	56(1422)	5-1/2(140)	72(1829)	8(203)	1-1/16(27)	52(1321)	96-3/8(2448)	51(1295)	3(76)	119-5/16(3031)	3(76)	28(711)	8-7/16(214)	39-5/16(999)
1800(6813)	64(1626)	56(1422)	5-1/2(140)	72(1829)	8(203)	1-1/16(27)	52(1321)	96-3/8(2448)	63(1600)	3(76)	131-5/16(3335)	3(76)	34(864)	8-7/16(214)	39-5/16(999)
2000(7571)	64(1626)	56(1422)	5-1/2(140)	72(1829)	8(203)	1-1/16(27)	52(1321)	96-3/8(2448)	75(1905)	3(76)	143-5/16(3640)	3(76)	40(1016)	8-7/16(214)	39-5/16(999)
2200(8328)	64(1626)	56(1422)	5-1/2(140)	72(1829)	8(203)	1-1/16(27)	52(1321)	96-3/8(2448)	87(2210)	3(76)	155-5/16(3945)	3(76)	46(1168)	8-7/16(214)	39-5/16(999)
2400(9085)	64(1626)	56(1422)	5-1/2(140)	72(1829)	8(203)	1-1/16(27)	52(1321)	96-3/8(2448)	100(2540)	3(76)	167-5/16(4250)	3(76)	52(1321)	8-7/16(214)	39-5/16(999)
2600(9842)	64(1626)	56(1422)	5-1/2(140)	72(1829)	8(203)	1-1/16(27)	52(1321)	96-3/8(2448)	113(2870)	3(76)	179-5/16(4250)	3(76)	58(1473)	8-7/16(214)	39-5/16(999)
2800(10599)	64(1626)	56(1422)	5-1/2(140)	72(1829)	8(203)	1-1/16(27)	52(1321)	96-3/8(2448)	125(3175)	3(76)	191-5/16(4555)	3(76)	64(1626)	8-7/16(214)	39-5/16(999)
3000(11355)	64(1626)	56(1422)	5-1/2(140)	72(1829)	8(203)	1-1/16(27)	52(1321)	96-3/8(2448)	137(3480)	3(76)	203-5/16(5164)	3(76)	70(1778)	8-7/16(214)	39-5/16(999)
3200(12112)	64(1626)	56(1422)	5-1/2(140)	72(1829)	8(203)	1-1/16(27)	52(1321)	96-3/8(2448)	46(3078)	3(76)	215-5/16(5469)	3(76)	76(1930)	8-7/16(214)	39-5/16(999)

NOTE:

These data sheets are the property of **LIFECO**. It shall not be reproduced, copied, lent in any manner or used for any other purpose other than that for which it is specially furnished, except by written permission of **LIFECO**.

We reserve the right to modify without prior notice for future development and enhancement of the product.

INSTALLATION, INSPECTION AND MAINTENANCE

An installation, inspection and maintenance manual is provided with each unit. The manual provides detail schematic, initial procedure, and inspection and maintenance procedures. The instruction manual must be read carefully and followed during installation and commissioning of the system.

After few initial successful test an authorized person must be trained to perform inspection and testing of the system. It is recommended to carry out physical inspection of the system regularly, the inspection should verify that no damages have taken place to any component and all the valves are in their proper position as per the system requirement. The system should be fully tested at least once a year and in accordance with applicable NFPA code or in accordance to the guidelines of the organization having local jurisdiction.

Do not turn off the system or any valve to repair or test the system, without placing a roving Fire Patrol in the area covered by the system. The Patrol should continue until the system is put back in service. Also inform the local security personnel and the Control Room so that a false alarm is not signaled.

CAUTION

1. Do not weld on the tank as it may damage the bladder.
2. Release pressure before an inspection and maintenance of the system.
3. Sight glass is not pressure tight, so before taking concentrate level reading, tank pressure must be released.
4. The bladder tank is to be installed under a shade to avoid direct sunlight on the equipment.

NOTE

The foam concentrate is to be filled in the bladder tank very carefully to avoid rupture of the bladder. The filling guideline provided with the equipment must be adhered to strictly.

NOTE:

These data sheets are the property of LIFECO. It shall not be reproduced, copied, lent in any manner or used for any other purpose other than that for which it is specially furnished, except by written permission of LIFECO.

We reserve the right to modify without prior notice for future development and enhancement of the product.