

Schematic Drawing

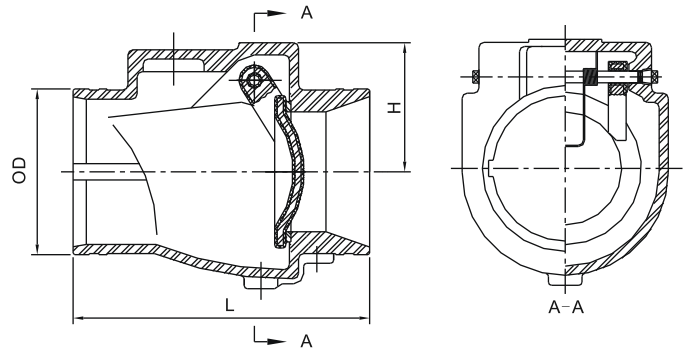

Features

- Full waterway design
- Seating type is resilient material to bronze seat construction
- Ductile iron disc EPDM encapsulated
- Groove ends to AWWA C606 standard or metric dimensions
- 300PSI (200PSI and 250PSI available on request)
- -10°C to 82°C Working temperature
- Fusion bonded epoxy coated interior and exterior to AWWA C550 standard corrosion protection.
- UL Listed for size 2.5", 3", 4", 5", 6", 8", 10" & 12"
- FM Approved for 2.5", 3", 4", 5", 6", 8", 10" & 12"

Material Specification

Part Name	Material	ASTM Spec.
Body	Ductile Iron	A536 65-45-12
Seat Ring	Bronze	B62 C83600
Disc	DI & Rubber Encapsulated	A536 65-45-12, EPDM
Spindle	Stainless Steel	AISI 316
Spring	Stainless Steel	AISI 304
Plug	Stainless Steel	AISI 304
Washer	Rubber	EPDM

Notes:

Design and material are subject to change without notice.

Dimensions (mm/inch)

Size	2"		2.5"		3"		4"		5"		6"		8"		10"		12"		
	mm	inch	mm	inch	mm	inch	mm	inch	mm	inch	mm	inch	mm	inch	mm	inch	mm	inch	
OD	ASTM	60.3	0.38	73.0	10	88.9	3.5	114.3	4.5	139.7	5.5	165.1	6.5	219.1	8.63	273	10.75	323.9	12.75
	BS			76.1	5.70					141.3	5.56	168.3	6.63						
L		190.5	7.5	203	8	213	8.39	245	9.65	267	10.5	292	11.5	356	14	432	17	495	19.49
H		65.5	2.58	74.5	2.93	78	3.07	102	4	112	4.41	133.5	5.26	160	6.30	195	7.68	215	8.46