



Matrix Network Vision Annunciator Information Guide





CONTENTS

Contents	2
Compliance	3
Underwriters Laboratories (UL)	3
FCC	3
Installation	3
Introduction	4
Technical Support	4
Return Material Authorization (RMA)	4
Warranty Service	5
Advanced Replacements	5
Overview	6
Fascia	7
Internal Components	8
Installation	9
Before You Begin	9
Mounting the Vision Annunciator	11
Trim Ring	12
Wiring	14
Specifications	17
Cabling	18
Index	19



COMPLIANCE

Underwriters Laboratories (UL)

Fire Alarm Subassembly
Lichfield Fire & Safety Equipment Co Ltd

FCC

This equipment has been tested and found to comply with the limits for a Class A digital device, pursuant to Part 15 of the FCC Rules. These limits are designed to provide reasonable protection against harmful interference when the equipment is operated in a commercial environment. This equipment generates, uses, and can radiate radio frequency energy and, if not installed and used in accordance with the Installation Manual, may cause harmful interference to radio communications. Operation of this equipment in a residential area is likely to cause harmful interference in which case the user will be required to correct the interference at his own expense. Any changes or modifications not expressly approved by Lichfield Fire & Safety Equipment Co Ltd could void the user's authority to operate this equipment under the rules and regulations of the FCC.

Operation is subject to the following two conditions:

- (1) This device may not cause harmful interference, and
- (2) This device must accept any interference received, including interference that may cause undesired operation.

Installation

Install this product in accordance with NFPA 13, NFPA 72, NFPA 70, and NEC 70 and all local codes.

All field wiring should be installed using fire rated cables according to the NFPA 72. Riser conductors shall be installed in accordance with the survivability from attack by fire requirements in National Fire Alarm Code, NFPA 72, Section 12.3. Riser conductors shall employ either a 2 hour rated cable system, or meet requirements approved by the AHJ.



INTRODUCTION

Technical Support

For technical support, contact Lichfield Fire & Safety Equipment Co. Ltd on +44 (0) 1902 798 706 or e-mail technicalsupport1@lifeco-uk.com.

Prior to contacting technical support, have the following information available:

- Product part number
- Purchase order or order number
- Product serial number
- Current function of the product
- Expected function of the product
- Installation of the product

Return Material Authorization (RMA)

Contact Technical Support to obtain an RMA for any product to be returned. Returns will not be accepted without an accompanying RMA number. An RMA number is assigned when:

- Tech Support acknowledges a possible product failure.
- A product was damaged during shipping
- An incorrect product was shipped
- An order was placed using an incorrect part number *
- An order was placed using an incorrect part quantity *
- An order is no longer required *

* Restocking fees may apply.

All returned products are tested to confirm operating failures experienced in the field. If the product is found to be functional, contractors must absorb expenses for return shipping, as well as the cost and shipping of the advanced replacement product.

Prominently display the RMA number on all packages sent for return. Ship all return products to:

Lichfield Fire & Safety Equipment Co. Ltd
Unit 8, Calibre Industrial Park
Laches Close,



Four Ashes,
Wolverhampton WV10 7DZ
United Kingdom

Warranty Service

Technical Support can replace or repair a defective product when the original purchase is within the warranty period defined in the sales contract. Check your contract for more information, or contact your sales representative about your specific warranty period.

Advanced Replacements

Products that fail to operate in the field can be replaced quickly using the advanced replacement process. The advanced replacement process is available to all contractors who maintain an acceptable line of credit.

Initiate the advanced replacement process by requesting an RMA number from a Tech Support representative. Advanced replacements can be shipped to your location when the product is covered under warranty and when a replacement product is in stock.

- Advanced replacements can be expedited at the request of the contractor. Shipping costs associated with this process are the responsibility of the contractor.
- Products returned using the advanced replacement process must be received within 30 days of the RMA issue date.

OVERVIEW



Matrix Network Vision Annunciator

LF-MC00NC-10

The Matrix Network Vision Annunciator is a display and control unit which duplicates the indications and primary controls of Matrix Fire Alarm Control Panels connected to the same network. The Annunciator connects via the network interface, and any number of repeaters can be connected up to the maximum number of nodes allowed by the network.

Matrix Network Vision Annunciators can be configured to replicate fire control panel functionality or to operate as simple, display-only devices for applications where access to fire alarm controls are inappropriate. The Annunciator can be configured to display events from any combination of nodes on the network.

Fascia



Internal Components

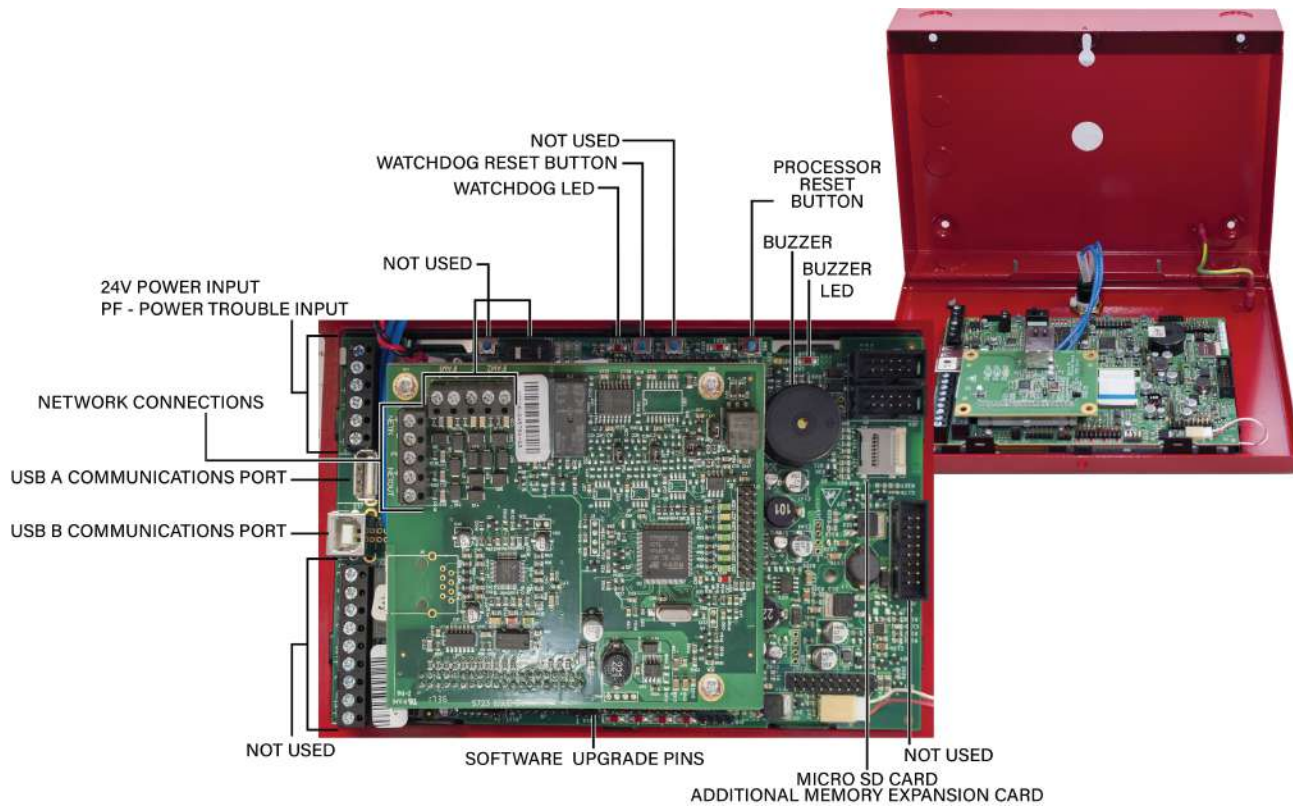



INSTALLATION

This section explains the installation procedure for the Matrix Network Vision Annunciator. Install this product in accordance with NFPA 72, the National Electrical Code, and all local codes.

- Notify the monitoring center and location security that the Matrix Fire Alarm Control Panel will be temporarily out of service.
- Remove the Annunciator from its packaging and check its contents.
- Remove the fascia.
- Mount the enclosure to wall.
- Reinstall the fascia.
- Remove AC and battery power from the panel.
- WARNING!** Failure to remove power during wiring and installation can damage the unit and void the warranty.
- Connect field wiring. Refer to [Wiring](#) below for specific details.
- Restore AC and battery power.
- Wait for the panel start-up process to complete. Refer to the **Matrix Fire Alarm Control Panel Installation Manual (MAN-1431LF-M)** for more information.
- From the Annunciator GUI, set the node number. This requires User Access Level 3.
- [Configure](#) the Annunciator and all nodes on the network.
- Test the Annunciator to verify proper operation based on the configuration.

WARNING! The Annunciator must be installed by personnel familiar with electronic components. Electronic components within the module are vulnerable to damage from electrostatic discharge. Ground straps must be worn by installers before handling to prevent electrostatic discharge damage.

Before You Begin

Before you begin the installation, take a few minutes to review the installation information, gather the required items, and complete the tasks listed to make the installation as quick and easy as possible. Acquire the following item(s) that are not included, but may be required for installation:



- **Ground Strap** - A ground strap is required for handling circuit boards. The ground strap is not provided in the packaging.
- **Mounting Hardware** - *Without Optional Trim Ring*: 4 #10 screws, appropriate for mounting location
With Optional Trim Ring: 4 M4 x 8mm machine screws and 4 M4 plain washers

Mounting the Vision Annunciator

1. Open the enclosure by removing the screw located at the top. The fascia hinges downwards. Remove the fascia by disconnecting the ground and removing the hinge pins.
2. Using the enclosure as a template, mark the position of the holes.
3. Mount the enclosure using appropriate hardware.

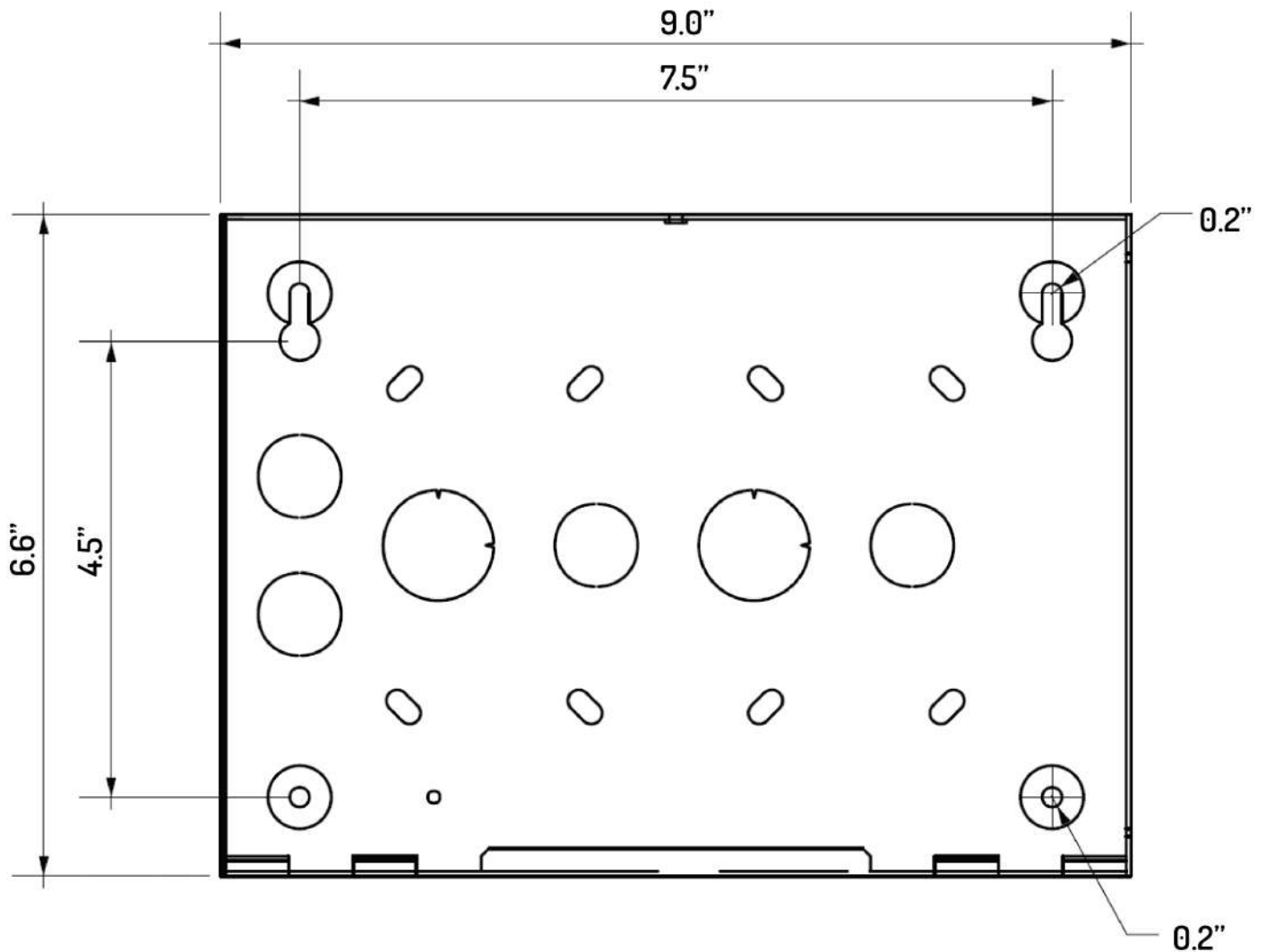

Trim Ring

The optional trim ring allows a semi-flush mounting of the surface enclosure back box. The diagram below shows the trim ring external and advised wall cut-out dimensions.

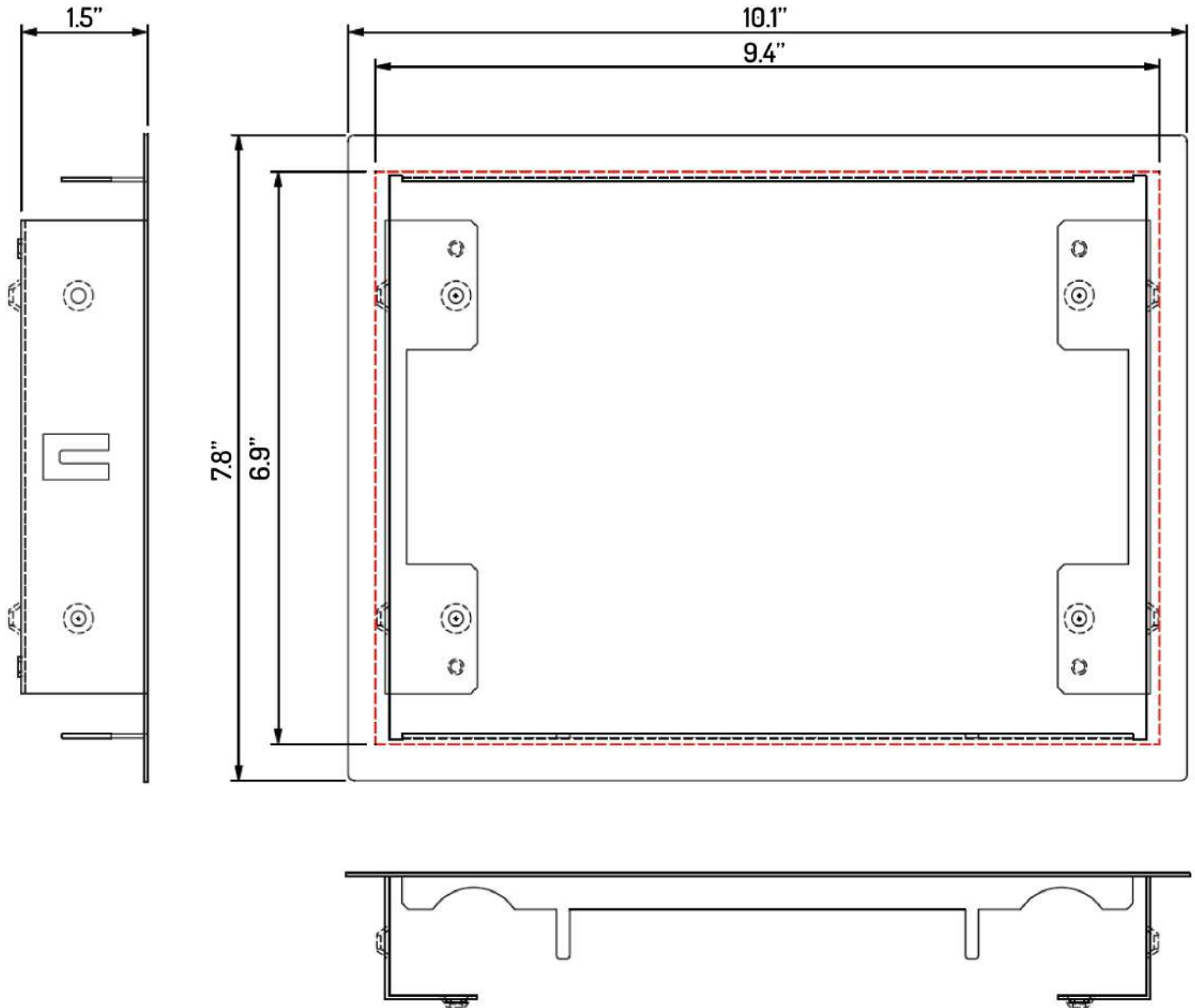

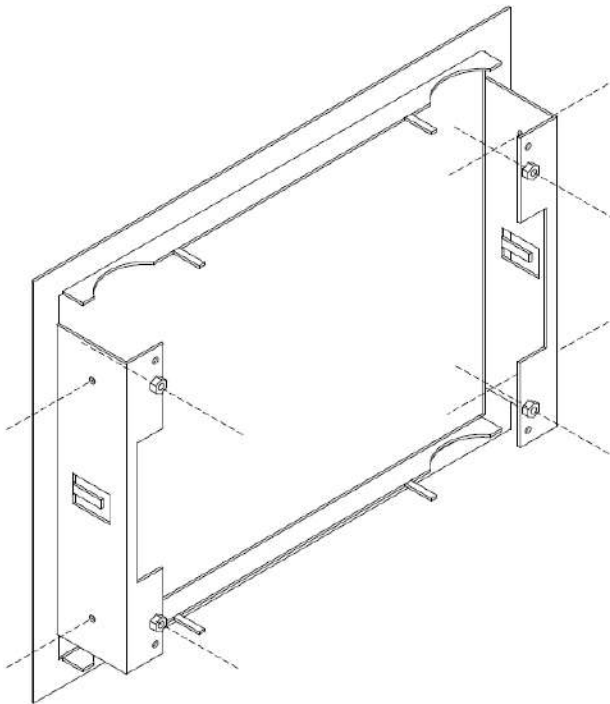

Trim Ring Fitting Options

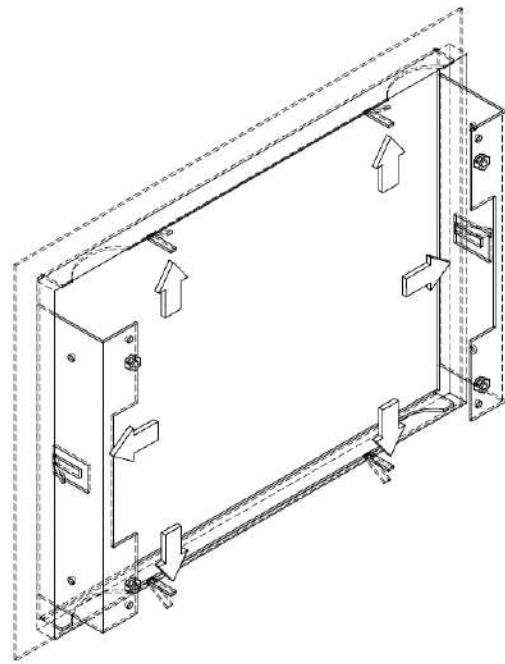

Trim Ring Fold Tabs

Use four, M4 x 8mm machine screws and M4 plain washers to mount the enclosure to the trim ring.

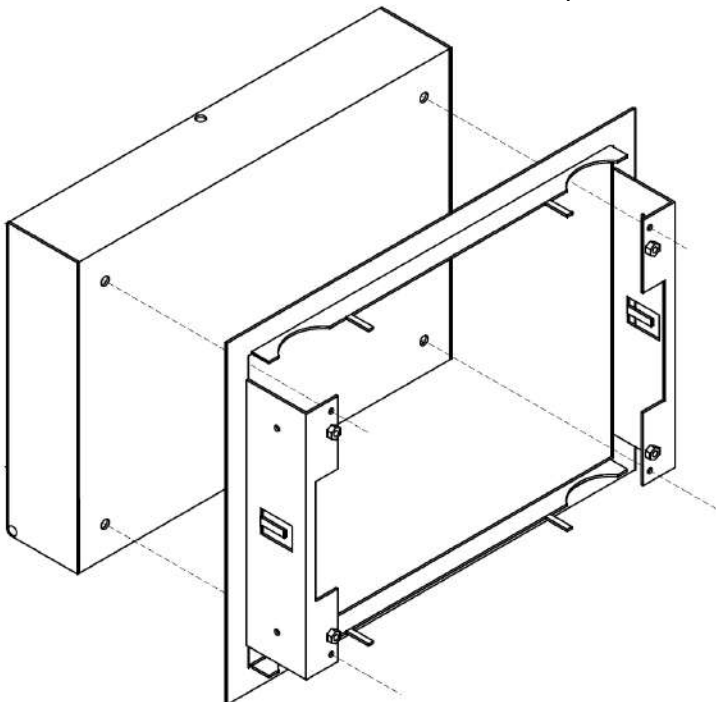

Wiring

The diagram below shows power and network connections when using a dedicated power supply.

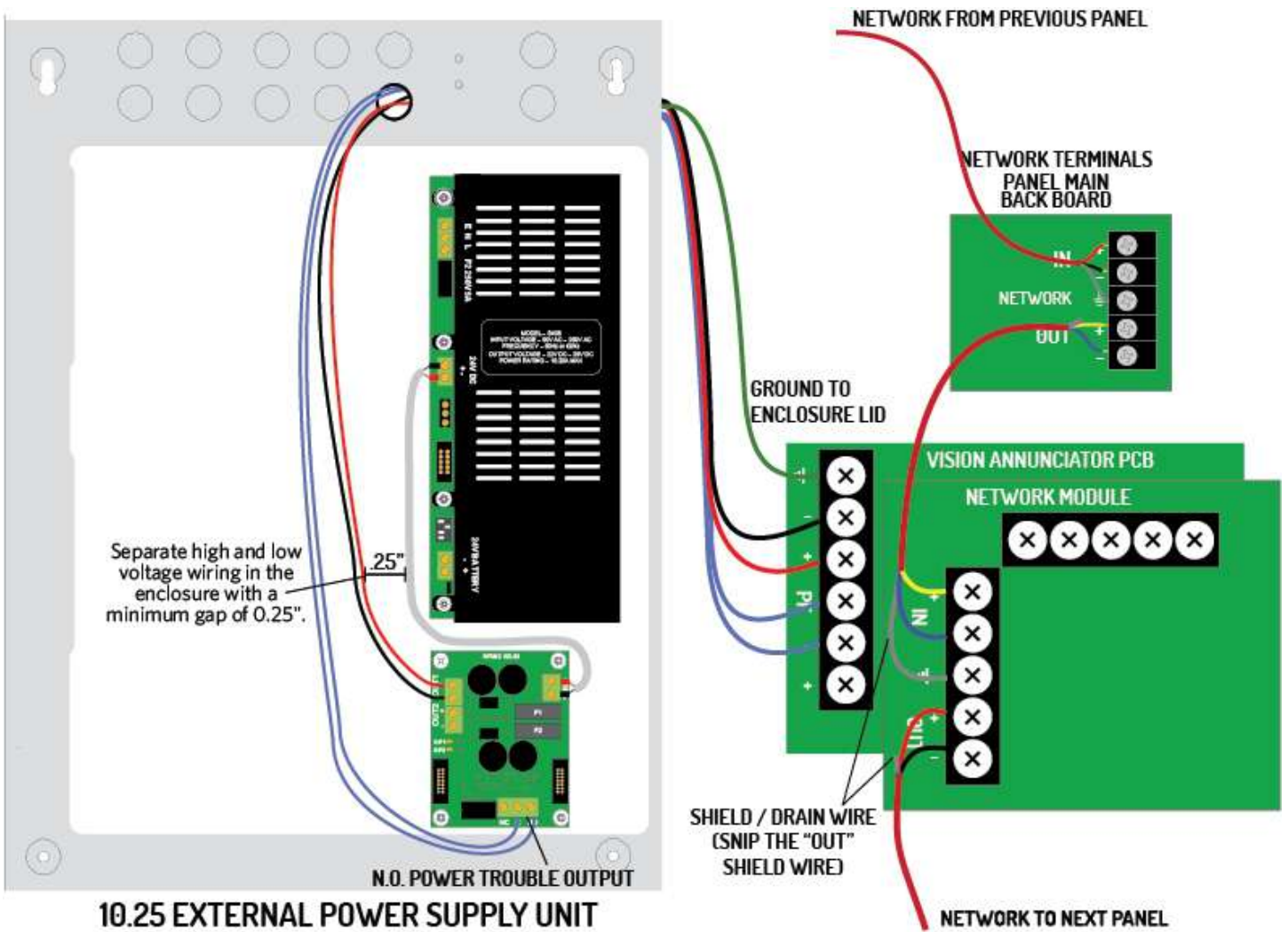

The diagram below shows power and network connections when powered from an adjacent Matrix panel. In this scenario, no PF is required. Power is supervised by the Matrix panel. Do not insert more than one conductor per terminal. Use wire nuts or other suitable splice connectors to connect the 24V DC cables to both the AUX 24V OUT and RTN terminals.

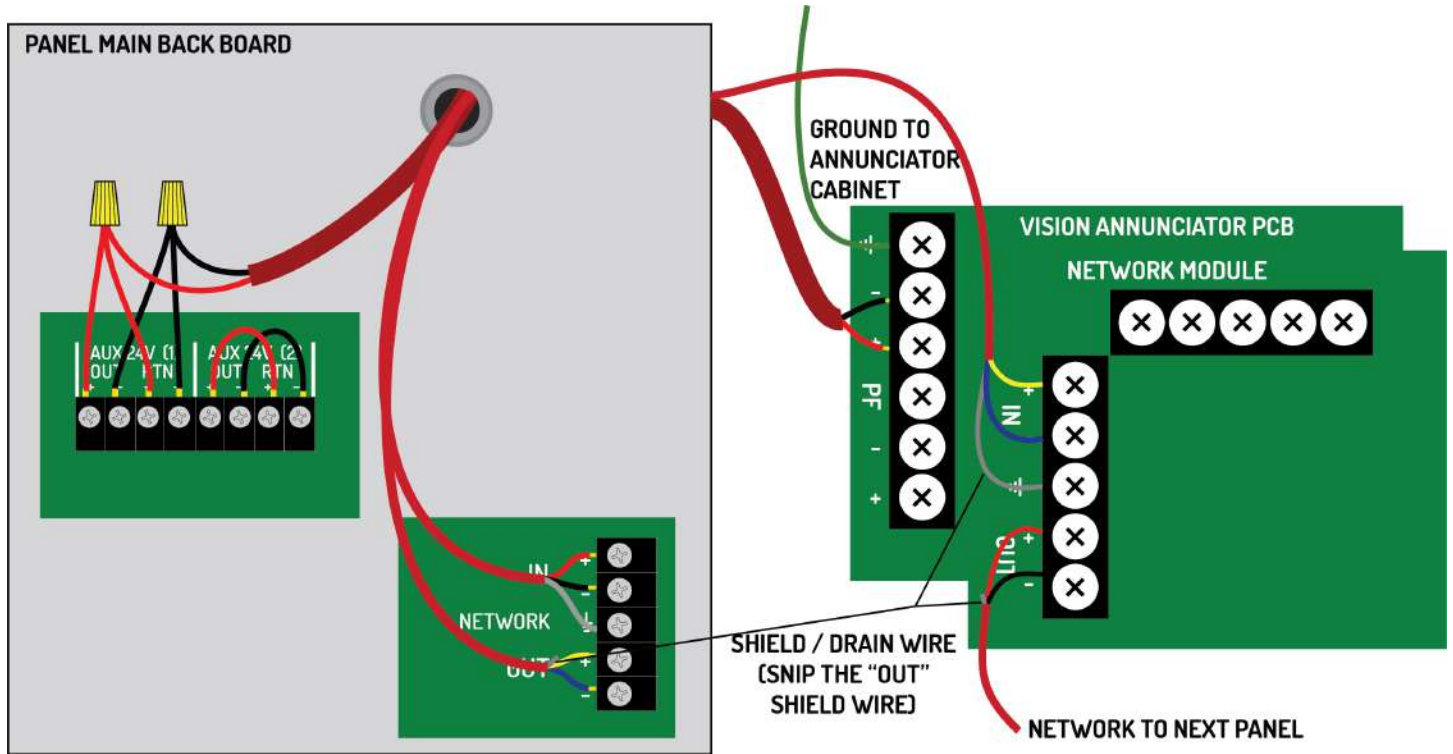

The diagram below shows an example network wiring scheme featuring two panels and two annunciators.

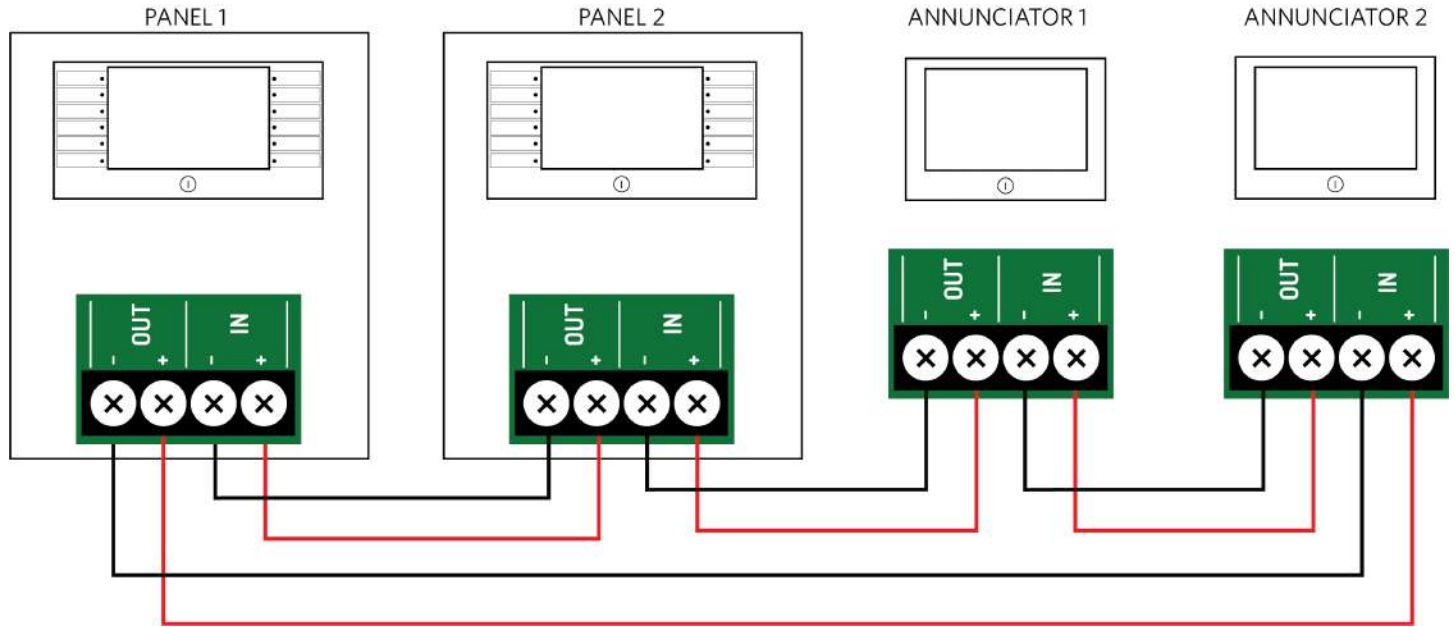



SPECIFICATIONS

Property	Description
Electrical	
24V supply	21 to 30 VDC
Quiescent current of unit in power failure	253mA typical (buzzer off @ 24V DC) 301mA typical (buzzer on @ 24V DC) 341mA max (buzzer on @ 21V DC)
Wire Size Range	14 - 18 AWG
Communication	
Max number of units on the network	31 annunciators
Cabling	RS-485 two-wire. Maximum distance from fire control panel: 3900 feet (1200 meters). Specify Belden 9271, 9860, or any 18 - 22 AWG insulated copper-wire.
Mechanical	
Size	9.25" x 6.7" x 2.2" (235 mm x 170 mm x 55 mm)
Display	Full color 800 x 480 LCD with resistive touch screen and automatic backlight dimming
Construction	18 SWG, 1.2mm mild sheet steel, IP30 rated
Cable Entry	2 x 20 mm knockouts on top & bottom 4 x 20 mm and 2 x 28 mm knockouts in back
Finish	Epoxy powder coated
Color	Red (RAL3002)
Weight	4.4 lbs (2 kg) maximum
Environmental	
Temperature Range	23°F (-5°C) - 120°F (49°C)
Relative Humidity	Up to 95%, non-condensing

Cabling

The 24V power cable must be sized appropriately to ensure proper input voltage under maximum load conditions. The maximum wire size, which can be terminated, is 14 AWG.

The specified transmission distance limit for the communications method used is 3900 feet (1200 meters). To guarantee operation of the system with one point of failure, it is necessary to arrange the cabling such that the failure will not introduce more than 3900 feet (1200 meters) of cable between the two points which would be connected together by the failure. This means that the total cable length between adjacent cable segments should not be more than 3900 feet (1200 meters). It is not important how this distance is made up (i.e., it could be 3000 feet + 900 feet, or 1950 feet + 1950 feet).

The following diagram shows an example of these cabling limitations.

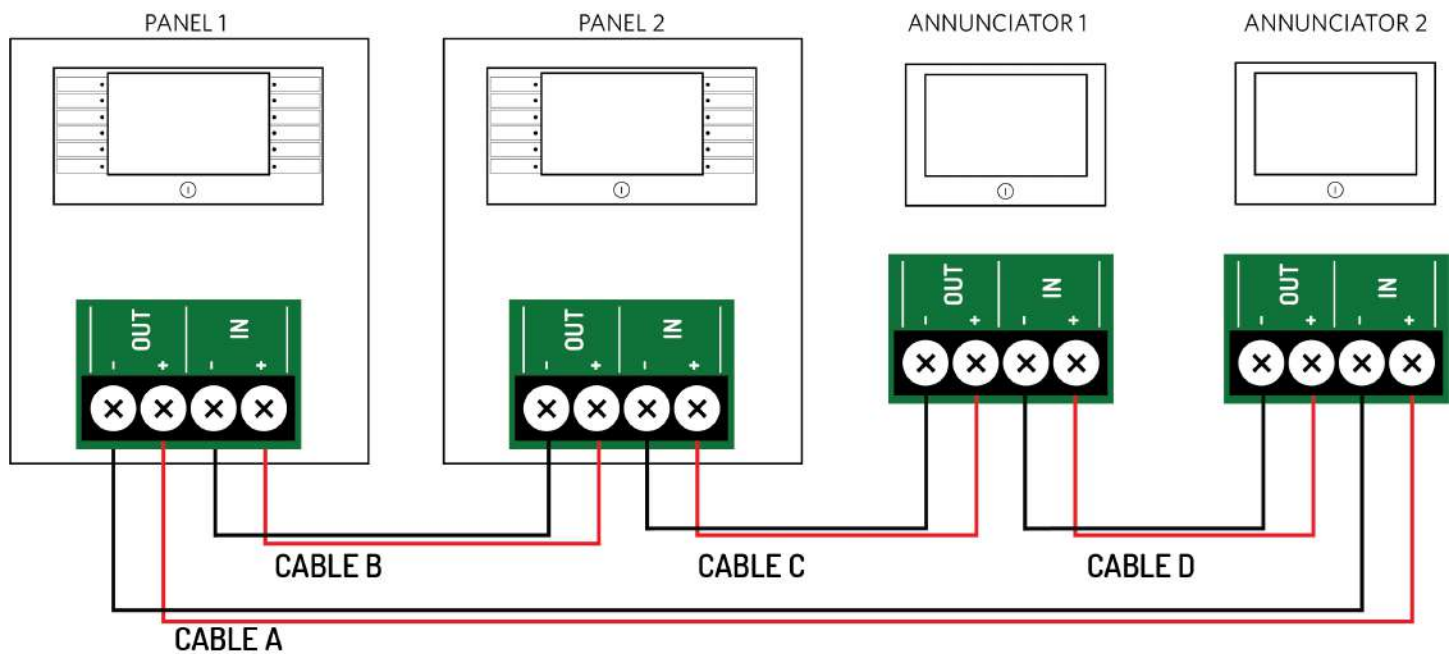

- The length of CABLE A + CABLE B cannot exceed 3900 feet (1200 meters).
- The length of CABLE B + CABLE C cannot exceed 3900 feet (1200 meters).
- The length of CABLE C + CABLE D cannot exceed 3900 feet (1200 meters).
- The length of CABLE D + CABLE A cannot exceed 3900 feet (1200 meters).

INDEX

1

14 AWG 18

18 AWG 17

2

24V 15, 17

A

AUX 24V 15

B

Buzzer 17

C

Cabling 17

Class A 3

F

Fascia 7, 9

N

Network 6, 9, 17

T

Terminals 15