

## Feature and Benefits

- EN 54-29:2015, EN 54-5: 2017 + A1: 2018, EN 54-7:2018 Compliance
- Using microprocessor technology with memory capacity up to 10 events
- Analogue sending and digital addressing
- Provide real time algorithm to the control panel
- Smart linear drift compensation
- 360 degree visual indicator
- Onsite Adjustable Parameter
- Removable chamber against dust and small insect
- Ancillary remote indicator output
- Aesthetically pleasing design



## Overview

The LF-X5120 Intelligent Multi-sensor Fire Detector is the ideal device for most applications, due to its spiffing linear response to a wide variety of different types of smoke patterns and combining with heat sensing sensor for temperature response. The unit manufactured base on the sensitivity requirement of EN 54 part 29, European Standard. The unit is aesthetically pleasing with unobtrusive design that will complement modern building designs. The unit incorporates an intelligent processor that provides Algorithm map, inbuilt A/D converter, Drift compensation, and Self-Diagnosis and History log.

Secure and speedy communication through the on-board processor enables the detector to make its own decision, resulting in greater automation. In the event of fire, the integral microprocessor analyses the signal according to factors such as signal strength and rate of increase, then confirms these patterns with the pre-programmed fire scenarios, smoke and heat patterns including rate of rise temperature, for a faster and safer response. Once it is confirmed, the LED indicates the sensor status and parallel sending communication signal to the control panel. The LF-X5120 detector is compatible to the LF-X500 Analogue Intelligent Fire Alarm Control Panel, produced by single manufacture LIFECO, to avoid addressable communication compatibility problem.

## Technical Specification

Listed	LPCB Certification
Compliance	EN 54-29:2015, EN 54-5: 2017 + A1: 2018, EN 54-7:2018
Input Voltage	24VDC [16V to 28V]
Current Consumption Standby	0.6mA, Alarm: 4mA
Protocol/Addressing	LIFECO, Value range from 1 to 254
Smoke Sensitivity	As per stipulated standard
Heat Class Type	A2R
Indicator	Single LED / 360 degree Visual
Material / Colour	ABS / White Glossy finishing
Dimension / Height	Diameter 99.7 mm / 57 mm
Weight	145g (with Base), 90g (without Base)
Operating Temperature	-10°C to +50°C
Humidity	0 to 95% Relative Humidity, Non condensing

**Detector and Wiring Details**

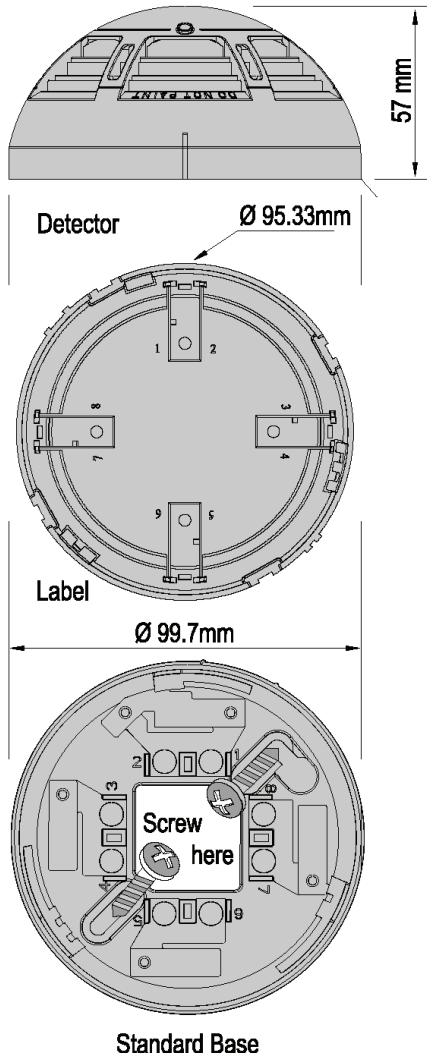

**Figure 1**

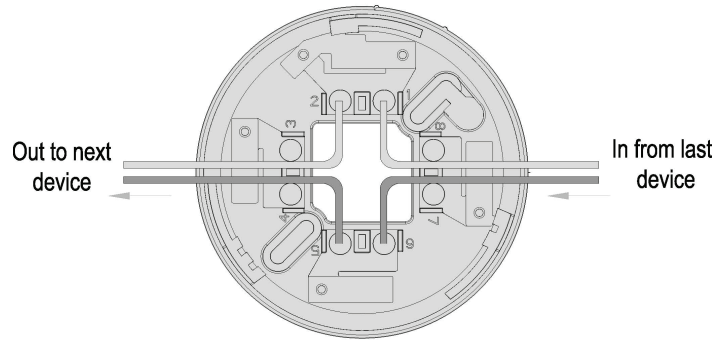

**Figure 2**

**Terminal Description**

1. Signal In (+)
2. Signal Out (+)
3. Remote Indicator (+)
4. Remote Indicator (+)
5. Signal In (-)
6. Signal Out (-)
7. Remote Indicator (-)
8. Remote Indicator (-)