

Technical Features

MODELS	LF-FCH1-C LF-FCH2-C LF-FCH3-C LF-FCH4-C	Carbon Steel construction
	LF-FCH1-S LF-FCH2-S LF-FCH3-S LF-FCH4-S	
INLET SIZE	2", 2.5", 3" & 4" (50, 65, 80, 100 mm)	
WORKING PRESSURE	Minimum 2.8 kg/sq.cm (40 psi) Maximum 7 kg/sq.cm (100 psi)	
FLANGE ANSI CONNECTION	B16.5 Class 150#SORF	
WEIGHT (Approx.)	2" (50 mm) - 29.9 kg 2.5" (65 mm) - 34.5 kg 3" (80 mm) - 49.5 kg 4" (100 mm) - 72.0 kg	
VAPOUR SEAL RUPTURE PRESSURE	0.7 to 1.75 kg/sq.cm (10 psi to 25 psi) Running water/ water foam solution pressure at inlet of Foam Chamber	
MAXIMUM PERMISSIBLE BACK PRESSURE ON VAPOUR SEAL	0.07 kg/sq.cm (1.0 psi)	
VAPOUR SEAL	Glass standard supply, Graphite optional only with UL Listed	
DEFLECTOR FINISH	Solid or Split Deflector Red RAL 3001 standard supply Other shades optional	
APPROVAL	UL Listed	
ORDERING INFORMATION	a) Model & Size b) Flow & Pressure at inlet of each Foam Chamber c) Inlet, outlet flange specification d) Type of Deflector e) Type of Foam concentrate used f) Tank number / Tag number	



Features

- UL Listed
- Heavy duty welded construction with choice of Carbon Steel or Stainless Steel material
- Frangible Glass Vapour Seal
- Controlled Air Flow proportional to liquid flow for optimum foam quality and rupture of vapour seal in narrow pressure tolerances for increased reliability
- Field replaceable orifice plate fitted with Foam Chamber

Applications

Foam Chamber is used in one of the most common applications to protect vertical fixed roof (cone) liquid storage tanks, with or without internal floating roof with the low expansion foam system. The application of foam is on the basis that the risk comprises the total surface area of the fuel. The foam system design guidelines generally used are in accordance with NFPA-11 standard. Foam Chambers are defined by NFPA-11 as Type II discharge outlets for delivering foam to the surface of a flammable liquid. Foam Chambers are widely used with the Balance Pressure Foam Proportioning System, Bladder Tank Proportioner or Foam Tender.

Specifications

Foam Chamber is an air aspirating foam discharge device, covering wide range of flow from 75 to 3300 litres per minute at 2.8 to 7 kg/sq.cm inlet pressure. The Foam Chamber contains a vapour seal to prevent the entry of fuel vapour into the foam chamber and the foam solution pipe. Each foam chamber is supplied with an orifice plate, designed for the required flow and inlet pressure. The orifice is field replaceable in the event of change in design parameters.

Foam is produced by introducing air into the foam solution stream. The inlet of foam chamber is designed to create venturi jet which draws air into the foam solution stream. Air is drawn into the foam solution through the holes located on the foam chamber covered with stainless steel screen to exclude nesting birds and insects. The aerated foam is directed into the deflector for gentle application of the expanded foam. The deflectors are available in different models.

Removal of cover plate from the top of the chamber allows the system to be tested and a sample of the expanded foam can be collected without removing the vapour seal or disconnecting the foam chamber from the tank. Frangible glass bursting disc/graphite (vapour seal) can be replaced easily.

The vapour seal is designed to rupture within 0.7 to 1.75 kg/sq.cm (10 to 25 psi) pressure at inlet flange of Foam Chamber, as required by NFPA, UL and FM standard. The vapour seal will withstand maximum back pressure of 0.07 kg/sq.cm (1.0 psi) or equal to 686 mm of water column as specified by API for welded storage tank. If the requirement exceeds 0.07 kg/sq.cm (1.0 psi) as in case of nitrogen blanketing system, then this equipment may not be suitable.

The vapour seal is frangible glass. Vapour seal is supplied with holder and for spares it can be with or without holder. The 'O' ring used for seal are Nitrile Rubber and optional Viton is recommended for polar solvent.

System Design Requirement

The NFPA-11, a standard for low expansion foam, provides the essential requirements of an appropriate designed foam pouring system, these are identified and outlined as below:

The Foam Deflector is used with the Foam Chamber. The aerated foam from the Foam Chamber is directed in to the deflector for the gentle application of the expanded foam. The deflector reduces the expanded foam velocity and allows the foam to slide down the tank wall.

(a) Number of Foam Chamber:

The number of foam chambers required is determined by tank diameter. Where two or more foam chambers are required, they shall be spaced equally around the tank periphery and each Foam Chamber shall be sized to deliver foam at an approximately same rate. Please refer graph to select unit that will provide required minimum foam solution application rate at the available operating pressure of the Foam Chamber.

For minimum number of Foam Chamber requirement, kindly follow the recommendations as per NFPA/OISD or as per the governmental codes or ordinances wherever applicable.

(b) Minimum Foam Solution Application Rate:

The minimum foam solution application rate is the rate at which the water and foam concentrate in correctly proportioned ratio should be delivered to the surface of a storage tank under protection to control and extinguish the fire.

For minimum application rate requirement, follow the recommendations as per NFPA/OISD or governmental codes or ordinances wherever applicable.

Testing & Maintenance

Carefully unpack Foam Chamber. While unpacking and installation it is to be handled with care and shocks to be avoided. Check visually for any damages. While installing ensure that Foam Chamber is not under stress due to any misalignments in installation or variations of system piping. Ensure that the strainer assembly is clear from any blockages or damages. If strainer assembly is either blocked or damaged, it will adversely affect the performance of the equipment.

Qualified and trained person must commission the system. After few initial successful tests, an authorized person must be trained to perform inspection and testing of the system.

It is recommended to carry out physical inspection of the system regularly. The system must be fully tested at least once in a year or in accordance with applicable NFPA/OISD standards or in accordance with authority having local jurisdiction.

Do not turn off the system or any valve to make repair or test the system, without placing a roving Fire Patrol in the area covered by the system. The Patrol should continue until the system is put back in service. Also inform the local security guard and control alarm station, so as to avoid false alarm.

Each system is to be flushed properly. The vapour seal must be replaced if the system has been operated. Normal testing of the chamber can be carried out by removing the cover plate from the top of the chamber. This allows the system to draw a sample of the expanded foam without removing the vapour seal or disconnecting the Foam Chamber from the tank.

The air screen is to be inspected periodically for the obstruction of air inlet holes. If any obstruction is noticed, remove the same and flush if necessary.

It is recommended to have regular maintenance programme to inspect the Vapour Seal Chamber discharge area and deflector for possible deposit or obstruction.

The owner is responsible for the testing, inspection & maintenance of the Foam Chamber.

Caution

Do not install Foam chambers on pressured storage tanks (Inert gas blanketed tanks) and storage tanks containing products, which may attack the foam chamber standard construction material. Maximum permissible back pressure on vapour seal is 0.07 kg/sq.cm (1.0 psi)

Note

A PROVISION IS TO BE MADE FOR PRESSURE GAUGE MOUNTING AT INLET OF FOAM CHAMBER, WHICH MAY BE PLUGGED AFTER SUCCESSFUL COMMISSIONING OF THE SYSTEM. THIS PROVISION WILL HELP TO ANALYSE THE SYSTEM WHILE COMMISSIONING.

Selection of HD Foam Chamber:

TABLE-1 gives the K-Factor of Foam Chamber at various pressures for selection of correct size of Foam Chamber. UL Approval have different Flow/K-factors.

TABLE-I

APPROVALS	UL LISTED
WORKING PRESSURE	2.8 To 7 kg/sq.cm
FOAM CONCENTRATE	AFFF3% & AR-AFFF 3X3%
MODELS	K-FACTOR
LF-FCH1-C & LF-FCH1-S	44.8 To 126.9
LF-FCH2-C & LF-FCH2-S	89.6 To 207.8
LF-FCH3-C & LF-FCH3-S	179.2 To 385.9
LF-FCH4-C & LF-FCH4-S	358.5 To 907.01

To select the size of the Foam Chamber use the following formula:

$$Q = K \sqrt{P}$$

Q = Total solution flow in litres per minute

K = Constant for Foam Chamber

P = Inlet pressure in kg/sq.cm.

Foam Chamber

MODEL	INLET SIZE	OUTLET SIZE	DIMENSIONS in millimeter (Approximate)		
			A	B	C
LF-FCH1-C LF-FCH1-S	50NB	80NB	676	520	175
LF-FCH2-C LF-FCH2-S	65NB	100NB	756	600	175
LF-FCH3-C LF-FCH3-S	80NB	150NB	1093	908	225
LF-FCH4-C LF-FCH4-S	100NB	200NB	1221	996	275

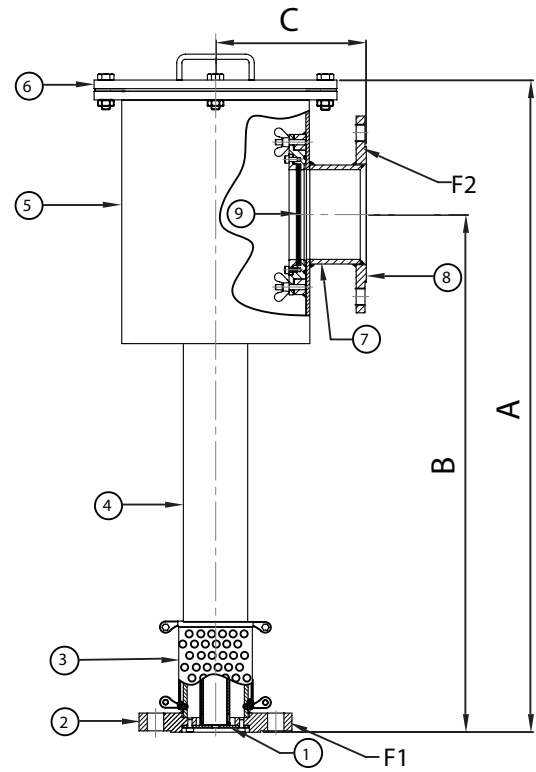

Part List

ITEM NO.	DESCRIPTION	MATERIAL SPECIFICATON	
		FCA	FCA-S
1	ORIFICE ASSEMBLY	STAINLESS STEEL	STAINLESS STEEL
2	INLET FLANGE	STEEL	STAINLESS STEEL
3	STRAINER ASSEMBLY	STAINLESS STEEL	STAINLESS STEEL
4	FOAM MAKING CHAMBER	STEEL	STAINLESS STEEL
5	FOAM CHAMBER	STEEL	STAINLESS STEEL
6	INSPECTION COVER	STEEL	STAINLESS STEEL
7	DISCHARGE PIPE	STEEL	STAINLESS STEEL
8	OUTLET FLANGE	STEEL	STAINLESS STEEL
9	VAPOUR SEAL ASSEMBLY	GLASS	GLASS

NOTE:

1. Strainer Assembly consists of SS perforated sheet, SS Strainer holder & Galvanised Nut/Bolt.
2. Vapour Seal is Glass as standard supply (UL Approved) & Graphite disc is optional.
3. Pipes used are ERW (Seamless Pipes are optional)
4. Foam chambers are open to atmosphere & do not have internal shutoff device, hence no hydrotest is offered during inspection.

Typical Foam Chamber Installation With Deflector

TYPICAL INSTALLATION OF FOAM CHAMBER WITH STUD MOUNTING PAD AND SPLIT DEFLECTOR

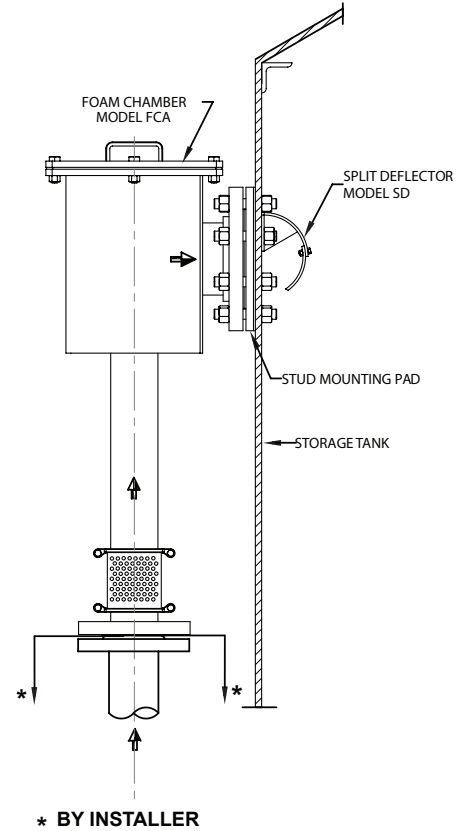
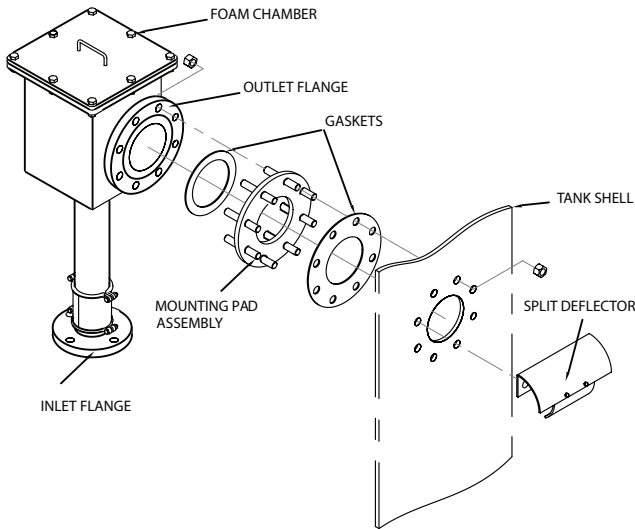

NOTE: Stud Mounting Pad with gasket & split deflector are optional items. To be ordered separately.

TANK CUTOUT FOR MOUNTING OF SPLIT DEFLECTOR

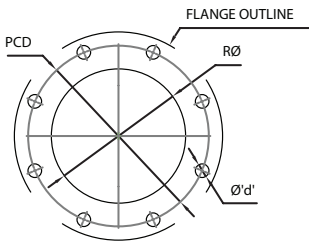

TYPE	FOAM CHAMBER SIZE		CUTOUT SIZE			
	INLET FLANGE SIZE	OUTLET FLANGE SIZE	RØ	PCD	HOLE Ø'd'	NO OF HOLES
FCH 1	50	80	90.7	152.4	19	4
FCH 2	65	100	116	190.5	19	8
FCH 3	80	150	170	241	22	8
FCH 4	100	200	221	298	22	8

TYPICAL INSTALLATION OF FOAM CHAMBER WITH STUD FLANGED TANK NOZZLE AND SOLID DEFLECTOR



GLASS VAPOUR SEAL WITH HOLDER (STANDARD SUPPLY)

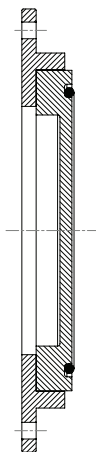

GRAPHITE VAPOUR SEAL WITH HOLDER, (OPTIONAL SUPPLY ONLY WITH FM APPROVAL)

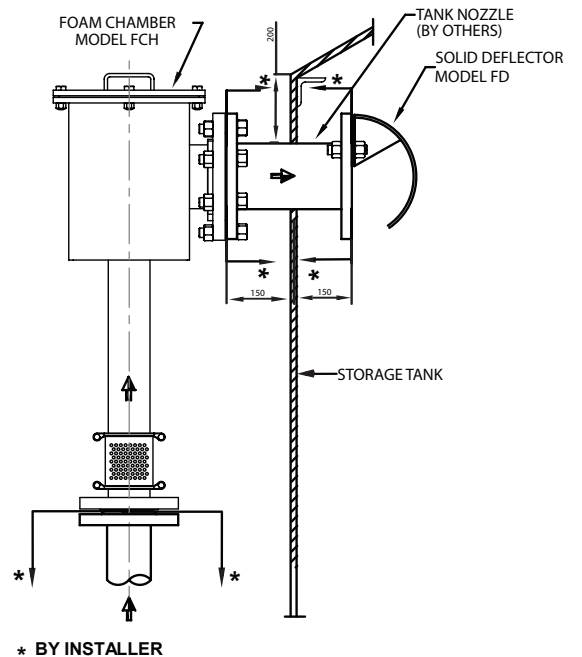

NOTE:

1. Above dimensions are general guidelines only. The system designer can adopt the dimensions as per NFPA/TAC/OISD or as per the governing rules & ordinance having local jurisdiction.
2. Tank nozzle, nut-bolts & gaskets are optional, to be ordered separately.
3. Split deflector Model SD and solid deflector Model FD is standard supply in carbon steel material and optional in stainless steel.

**Pressure vs flow performance characteristic
UL listed with foam concentrate AFFF 3% & AR-AFFF 3x3%**

