

Technical Features

MODEL	LF-FM1-C, LF-FM2-C - Carbon Steel Construction LF-FM1-S, LF-FM2-S - Stainless Steel Construction
INLET SIZE	2" & 2.5"(50 & 65mm)
WORKING PRESSURE	Minimum 2.8 kg/sq.cm (40 psi) Maximum 7 kg/sq.cm (100 psi)
FLANGE ANSI CONNECTION	B16.5 class 150#SORF
FINISH	Red RAL 3001 standard supply Other shade optional
WEIGHT	50 NB - 9.9 kg (Approx.) 65 NB - 14.0 kg
APPROVAL	UL Listed (Refer Table-I)
ORDERING INFORMATION	Specify: a) Model and inlet size b) Inlet pressure c) Flow Solution flow required. d) Inlet Outlet flange e) Type of Foam Concentrate used



Applications

Foam Maker is used for one of the most common applications of protecting tank seal in vertical liquid storage tank with internal floating roof with low expansion foam system. The application of aspirated foam is on the basis of the risk comprising the area in the annular ring between the rim of the floating roof and the tank shell. The Foam system design guidelines generally used are in accordance with NFPA11 standard. The Foam Makers are defined by NFPA 11 as Type II discharge outlets for delivering the low expansion aspirated foam to the seal. The Foam Makers are widely used with the Inline Foam Inductor, Balance Pressure Foam Proportioning system, Bladder Tank system and Foam tenders.

Specifications

Foam Maker is an air aspirating foam generator connected to the foam pourer to deliver the aspirated foam gently into the tank seal area. Foam maker covers wide range of foam solution rates from 75 to 557 litres per minute at 2.8 to 7 kg/sq.cm inlet pressure. The orifice is field replaceable in the event of change in design parameters. The foam is produced by introducing air into the foam solution stream.

The inlet of foam maker is designed to create venturi jet which draws air into the foam solution stream. The air is drawn into the foam solution through holes located on the foam maker covered with stainless steel screen to exclude nesting birds and insects. The aerated foam is directed into the pourer for the gentle application of the expanded foam. The pourers are available in different models.*

Installation, Testing and Maintenance

Carefully unpack Foam Maker. While unpacking and installation, it is to be handled with care and shocks to be avoided. Check visually for any damages. While installing, ensure that the Foam Maker is not under stress due to any misalignments in installation or variations of system piping. Ensure that the strainer assembly is clear from any blockages or damages. If strainer assembly is either blocked or damaged will adversely affect the performance of the equipment.

Qualified and trained person must commission the system. After few initial successful tests, an authorized person must be trained to perform inspection and testing of the system. It is recommended to carry out physical inspection of the system regularly. The system must be fully tested at least once in a year or in accordance to standards of the organization having local jurisdiction.

Do not turn off the system or any valve to make repair or test the system, without placing a roving Fire Patrol in the area covered by the system. The Patrol should continue until the system is put back in service. Also inform the local security guard and control alarm station, so as to avoid false alarm.

Each system is to be flushed properly. To test the Foam Maker without discharging the foam into the tank seal area, the foam maker is to be rotated 180° away from the wind shield. The air screen is to be inspected periodically for obstruction of air inlet holes. If any obstruction is noticed, remove the same and flush if necessary. The foam maker outlet and pourer, if exposed to atmospheric condition, should be periodically inspected for nest and other obstructions. Any obstruction if noticed must be removed and flushed to clear the discharge path.

Note

1. A PROVISION IS TO BE MADE FOR PRESSURE GAUGE MOUNTING AT INLET OF FOAM MAKER, WHICH MAY BE PLUGGED AFTER SUCCESSFUL COMMISSIONING OF THE SYSTEM. THIS WILL HELP TO ANALYSE THE SYSTEM WHILE COMMISSIONING.
2. THE OWNER IS RESPONSIBLE FOR THE TESTING, INSPECTION AND MAINTENANCE OF THE FOAM MAKER AND THE SYSTEM.
3. REFER TO THE INDIVIDUAL FOAM UL LISTING FOR OPERATING AND LIMITATION WITH EACH FOAM CONCENTRATE AND FOAM MAKER.

Selection of LIFECO Foam Maker:

To select the size of the Foam Maker use the following formula:

$$Q = K \sqrt{P}$$

Where,

Q = Total solution flow in litres per minute.

K = Constant for Foam Chamber

P = Inlet pressure in kg/sq.cm

Example:

To find K factor: Q = 150 lpm

P = 3.5 kg/sq.cm

$$K = 150 \div \sqrt{3.5} = 80.17$$

The K-Factor 80.17 falls within the range of the Foam Maker having 50NB size. Hence 50NB size Foam Maker to be selected.

The Foam Maker can also be selected by using graph.

TABLE I - Selection of 50 NB LIFECO Foam Maker

FOAM CONCENTRATE	AFFF 3%
* APPROVALS	UL LISTED
WORKING PRESSURE	2.8 to 7 kg/sq.cm
K-FACTOR	44.8 to 126.6

TABLE II - Selection of 65 NB LIFECO Foam Maker

FOAM CONCENTRATE	AFFF 3%
* APPROVALS	UL LISTED
WORKING PRESSURE	2.8 to 7 kg/sq.cm
K-FACTOR	89.6 to 207.8

* Refer to UL directory for specific foam concentrate, working pressure and flow

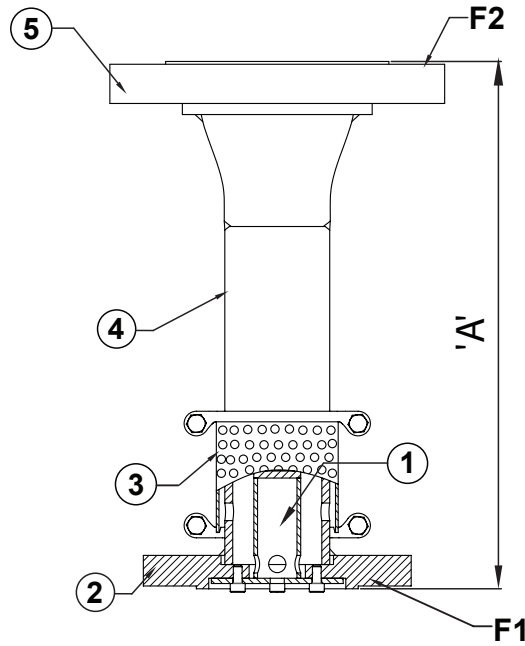

Dimensions of Foam Maker
in millimeter (Approximate)

MODEL	FOAM MAKER SIZE	INLET (F1)	OUTLET (F2)	A
LF-FM1-C & LF-FM1-S	50NB	50NB	80NB	300
LF-FM2-C & LF-FM2-S	65NB	65NB	100NB	400

Parts List

ITEM NO.	DESCRIPTION	MATERIAL SPECIFICATION	
		LF-FM-C	LF-FM-S
1	ORIFICE ASSEMBLY	STAINLESS STEEL	STAINLESS STEEL
2	INLET FLANGE	STEEL	STAINLESS STEEL
3	STRAINER ASSEMBLY	STAINLESS STEEL	STAINLESS STEEL
4	FOAM MAKING CHAMBER	STEEL PIPE	SS PIPE
5	OUTLET FLANGE	STEEL	STAINLESS STEEL

Note

Strainer Assembly consists of SS perforated sheet, SS Strainer holder & Galvanised Nut/Bolt.

Typical Installation of Foam Maker With Pourer

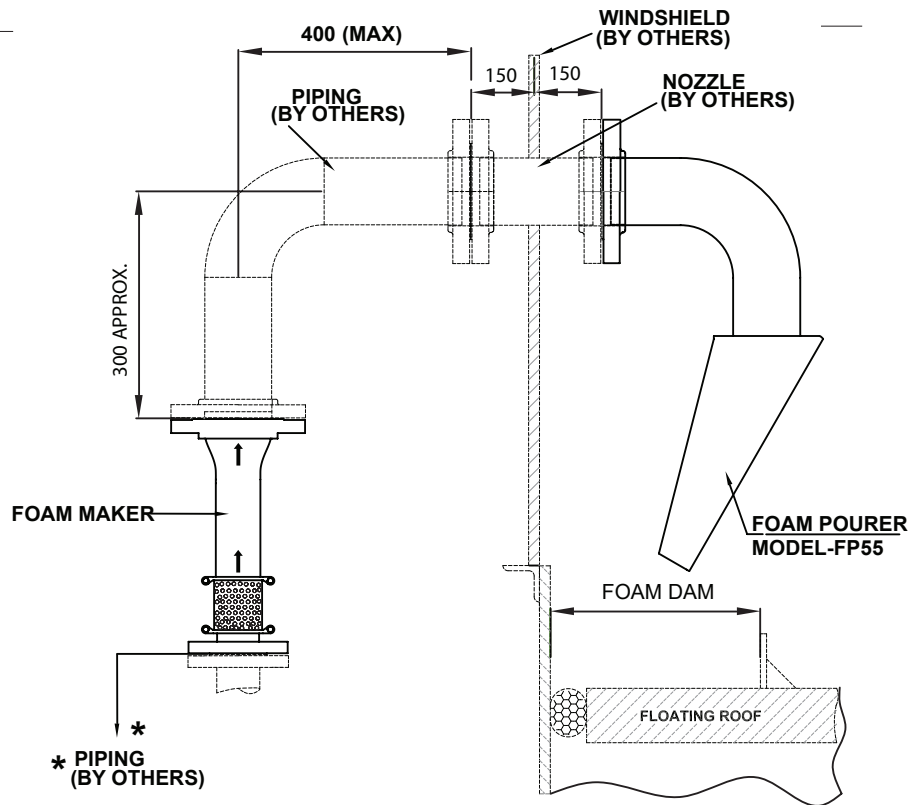

Note

1. Above dimensions (in mm) are for general guidelines only. The system designer can adopt the dimensions as per NFPA/OISD or as per the governing rules & ordinance having local jurisdiction.
2. Foam Pourer Model - FP55 is standard supply in carbon steel material and optional in stainless steel.

Pressure Vs Flow Performance Characteristic UL Listed With Foam Concentrate AFFF 3%

